

Instrument #: 2020-07117  
07/16/2020 10:14:38 AM Total Pages: 60  
XMS MISCELLANEOUS  
Recording Fee: \$ 302.00  
Polly Glascock, Recorder, Warren County Iowa



\$ 302.00  
JG  
WEA

R/  
ENC

Prepared by and Return to: Jake Oeth, Hogan Law Office, 3101 Ingersoll Ave, Ste 103, Des Moines, IA 50312 (515) 279-9059

**DECLARATION OF SUBMISSION OF PROPERTY TO  
HORIZONTAL PROPERTY REGIME  
FOR  
HERITAGE HILLS VILLAGE TOWNHOMES**

**THIS DECLARATION OF SUBMISSION OF PROPERTY TO HORIZONTAL PROPERTY REGIME** (this "Declaration") is made by **GROUND BREAKER HOMES, LLC**, an Iowa limited liability company ("Declarant"), owner and developer of the real estate described in **Exhibit "A"** (the "Land").

**WHEREAS**, Declarant intends to subdivide the Land into separate parcels of real estate for condominium ownership under this Declaration pursuant to the provisions of Chapter 499B, Code of Iowa, entitled "Horizontal Property (Condominiums)".

**WHEREAS**, it is the purpose of Declarant by recording of this Declaration to submit and convey the Land, together with all buildings, structures, improvements and other permanent fixtures of any kind constructed or hereafter to be constructed thereon, and all rights and privileges belonging or in any way pertaining thereto, to a condominium form of ownership and use as a Horizontal Property Regime under Chapter 499B of the Iowa Code to be known as "**Heritage Hills Village Townhomes**" and to impose upon such Land mutually beneficial restrictions under a general plan of improvement for the benefit of all Units and the Owners thereof.

**WHEREAS**, Declarant intends that this Declaration shall be in force and take effect from and after the date that it is recorded in the office of the County Recorder, subject to further amendment as provided herein.

**NOW, THEREFORE**, Declarant does hereby declare that all of the Land is held and shall be held subject to the following covenants, conditions, restrictions, reservations, uses, limitations, and obligations, all of which are declared and agreed to be in the furtherance of a plan for the improvement of the Land and the division thereof into condominiums and shall run with the land and shall be a burden and a benefit to Declarant, its successors and assigns, and any Persons owning an interest in the real property, improvements and appurtenances thereto, their grantees,

successors, heirs, executors, devisees and assigns.

## ARTICLE I DEFINITIONS AND GENERAL

For purposes of this Declaration and as used herein, the following terms shall have the following definitions, except as otherwise specifically provided:

**Section 1.** “Act” shall mean and refer to the Horizontal Property Act, Chapter 499B, Code of Iowa.

**Section 2.** “Additional Land” shall mean and refer to any real property annexed and submitted to the Condominium Regime.

**Section 3.** “Association” shall mean and refer to the **Heritage Hills Village Townhomes Association, Inc.**, a non-profit corporation organized pursuant to Chapter 504 Revised of the Code of Iowa, and its successors and assigns and refers to the "Council of Co-Owners" as defined in the Act.

**Section 4.** “Board of Directors” shall mean and refer to the members of the Board of Directors of the Association duly elected in accordance with the Bylaws and refers to the “Board of Administration” as defined in the Act.

**Section 5.** “Building” shall mean and refer to any structure containing one or more single-family dwelling units within the Condominium Regime and shall include any attached garage.

**Section 6.** “Bylaws” shall mean and refer to the Bylaws of the Association adopted by the Members, as the same may be amended from time to time.

**Section 7.** “City” shall mean and refer to the City of Indianola, in Warren County, Iowa.

**Section 8.** “Common Elements” shall mean and refer to all General Common Elements and Limited Common Elements as defined herein owned in common by all the Owners of the Units.

**Section 9.** “Condominium Property” shall mean and refer to all the Land submitted to the Condominium Regime under this Declaration, and includes all improvements and structures now or hereafter erected or constructed thereon, including the Buildings, the Storm Water Detention Facilities, and all easements, rights and appurtenances belonging thereto.

**Section 10.** “Condominium Regime” shall mean and refer to **Heritage Hills Village Townhomes**, a Horizontal Property Regime established upon the Land in accordance with the Act and this Declaration.



**Section 11.** “Control Period” shall mean and refer to the period commencing on the date this Declaration is filed of record with the County Recorder and terminating at such time as Declarant no longer has any ownership interest in the Condominium Property, unless sooner terminated by Declarant.

**Section 12.** “County Recorder” shall mean and refer to the office of the Recorder for Warren County, Iowa.

**Section 13.** “Declarant” shall mean and refer to Ground Breaker Homes, LLC, an Iowa limited liability company, and any successors and assigns acquiring all of Declarant’s ownership interest in the Land for purposes of development or improvement and who is specifically designated as the successor Declarant in an instrument executed by the immediately preceding Declarant filed of record with the County Recorder.

**Section 14.** “Declaration” shall mean and refer to this Declaration of Submission of Property to Horizontal Property Regime for Heritage Hills Village Townhomes to which the Land is subject.

**Section 15.** “General Common Elements” shall mean and refer to all portions of the Land and all improvements, including the Buildings and facilities thereof situated on the Land, except the Unit and such portions which are defined or reserved as Limited Common Elements. The General Common Elements include, without being limited thereto, all property defined as such in Section 499B.2(4), Code of Iowa, and shall include the following in the Condominium Regime:

- (a) The Land and beneficial easements.
- (b) Outlot Z in Heritage Hills Plat 10, together with any improvements thereon, which shall be appurtenant to each Unit and shall pass with the ownership of each Unit as an appurtenance hereunder. At the time of conveyance, each instrument of conveyance of a Unit shall be deemed to convey Outlot Z as a General Common Element in conjunction with the respective Unit without necessity of naming the same.
- (c) The Storm Water Detention Facilities.
- (d) The foundation, slabs, columns, beams, roof, attic, gutters, downspouts, exterior walls and other structural elements of the Buildings not reserved to a Unit.
- (e) Any interior load bearing walls, walls separating Units, except the interior surfaces thereof.
- (f) The exterior surface of the Buildings, excluding all interior and exterior parts of the windows and doors (i.e. glass, trim, head, sash frame, extension jamb, interior casing, exterior brickmold casing and sill), and excluding garage doors, entry doors, storm doors, stoops, decks, patios and any other exterior improvements made to the Units whether or not approved by the Association (for example, antenna, satellite



dish or similar reception devices, flags, or permanent barbeque grills for outdoor living).

- (g) The yard surrounding the Buildings, including the lawn, landscaping and plantings, buffer areas, retaining walls, and irrigation system (if any) and excluding any gardens, plants, flowers, trees, shrubbery and other landscaping planted by an Owner with the approval of the Association.
- (h) Public sidewalks (excluding service walks from driveways to the Unit entry doors or landings).
- (i) Outside lighting system and fixtures, all ventilation and exhaust systems, airways, chimneys, fresh air ducts and related equipment.
- (j) All sewer, water, electrical, gas, telecommunications and other utility facilities located within the Land that provides service to the Units, or service lines, conduits, ducts, plumbing, wiring, pipes and other facilities and systems within the attic or basement of any Building that provides services such as ventilation, exhaust, heating, air and air conditioning.
- (k) Entrance monument and features and directional signs abutting street rights-of-way utilized by the Condominium Regime.
- (l) Mailbox system as required by the U.S. Postal Service utilized by the Condominium Regime.
- (m) All other elements of the Condominium Property for common use or necessary to the existence, upkeep and safety of the Condominium Regime.

**Section 16.** “Land” shall have the meaning set forth on Exhibit “A”.

**Section 17.** “Limited Common Elements” shall mean and refer to such common property which is classified as limited by Section 499B.2(6), Code of Iowa and those portions of the Condominium Property set aside and allocated for the restricted use of a Unit including, but is not limited to, the following:

- (a) Driveways adjacent to and providing access to the Units, sidewalks or service walks leading from the driveways to the stoops, Unit entry doors or landings.
- (b) Stoops, patios and decks.
- (c) Service water lines from the main to the Unit.
- (d) Doors and windows, including any window set in the wall of a Unit.
- (e) Non-load bearing partitions or walls within a Unit (but excluding any lines, wires,



ducts and the like situated within such partitions).

- (f) Air conditioning and heating equipment servicing solely a Unit, whether located inside or outside of the Unit.
- (g) Sewer, water, electrical, gas, telecommunications or other utility or service lines, plumbing, wiring, ducts, conduits, piping, facilities, systems, fixtures, attachments, machines and equipment serving just one Unit and located entirely within the Unit, or servicing solely a Unit and considered a part of the Unit.
- (h) Flowers, plantings, gardens, trees, shrubbery and other landscaping planted by the Owner subject to the approval of the Association.

**Section 18.** “Member” shall mean and refer to those Persons entitled to membership in the Association as provided in the Articles of Incorporation and Bylaws of the Association, this Declaration and any recorded condominium document for the Condominium Regime.

**Section 19.** “Owner” shall mean the holder of a real property interest in a Unit, except when otherwise defined in this Declaration, and excluding mortgagees not in possession, lienholders and interests merely collateral in nature and refers to a "Co-Owner" as used in the Act and shall have the same meaning as the term "Member" as used in this Declaration and the Bylaws

**Section 20.** “Person” shall mean and refer to an individual, corporation, partnership, limited liability company, association, estate, trust, or other legally recognized form of entity, or fiduciary acting on behalf of another individual or any other legal entity.

**Section 21.** “Storm Water Detention Facilities” shall mean and refer to the storm water drainage and detention basin and all pipes, inlets and outlets appurtenant thereto and includes Outlot Z.

**Section 22.** “Supplemental Declaration” shall mean and refer to a separate instrument of declaration executed by Declarant and filed of record with the County Recorder that amends this Declaration to annex and submit Additional Land to the Condominium Regime.

**Section 23.** “Unit” shall mean and refer to any portion of a Building designated and intended for use and occupancy as a residence by a single family or individual and the garage appurtenant thereto. Each Unit consists of the area between the interior surfaces of its perimeter walls (including windows and sliding doors, garages, interior surface of exterior doors and between the lower surface of the ceiling and the upper surface of the lowest floor). In all cases, a Unit shall include and be defined by the surfaces referred to and including any non-load bearing partitions within, except that all lines, wires, ducts and the like within any non-load bearing partition or wall shall be excluded and shall not constitute a part of the Unit for purposes of separate ownership of such Unit. The term "Unit" shall have the same meaning as "Apartment" as defined in the Act, except as further defined in this paragraph.



**Section 24.** Plural and Gender. Whenever the context so permits or requires, the singular shall include the plural and the plural the singular, and the use of any gender shall include all genders.

**Section 25.** Successors, Grantees and Assigns. Reference to Declarant, an Owner, a Member or any Person shall include the respective heirs, successors, grantees and assigns thereof.

**Section 26.** Severability. The invalidity of a covenant, restriction agreement, undertaking, or other provision of any condominium document shall not affect the validity of the remaining portions thereof.

**Section 27.** Incorporation. Exhibits attached hereto and referred to herein are hereby made a part hereof with the same force and effect as other provisions of this Declaration; provided that, wherever specifically provided, modification of certain Exhibits shall not be deemed an amendment of this Declaration.

**Section 28.** Governing Law. This Declaration and the Bylaws shall be construed and controlled by and under the laws of the State of Iowa. A violation of either this Declaration or the Bylaws shall be deemed a violation also of the other.

**Section 29.** Other Definitions. Certain other terms are defined at various places in this Declaration and to the extent not defined herein, the definitions contained in the Act shall control.

## **ARTICLE II IDENTIFICATION OF LAND, BUILDINGS AND UNITS**

**Section 1.** Location of Land and Improvements. The Land and improvements hereby submitted to the Condominium Regime are located in Indianola, Warren County, Iowa and is legally described in Exhibit "A".

**Section 2.** Identification of Buildings and Units. The Condominium Regime will consist of ten (10) one-story Buildings comprising two (2) single-family Units constructed with standard building materials, including concrete, metal, wood, siding, shingles, and glass. All Units include an attached garage. The Units are shown and designated on the Site Plan drawing attached as Exhibit "B". A general description of the floor plans designed for the Units is attached as Exhibit "C". Exhibits "A", "B" and "C" are intended to meet the requirements set forth in Section 499B.4 and 499B.6 of the Code of Iowa.

**Section 3.** Expansion of Condominium Regime. Declarant reserves the right to expand the Condominium Regime subject to this Declaration from time to time by subsequent Supplemental Amendments by adding additional Buildings and Units on Additional Land.



**ARTICLE III**  
**OWNERSHIP OF UNITS AND COMMON ELEMENTS**

**Section 1.** Exclusive Ownership of Unit. Each Unit Owner shall be entitled to exclusive ownership and possession of his Unit in the Condominium Regime. Notwithstanding the reservations permitted herein, the design and layout of the Buildings and Land submitted to the Condominium Regime and the integrity and appearance of the Condominium Regime as a whole, are the common interest of all Owners and shall remain a part of the Common Elements.

**Section 2.** Appurtenances – Common Elements. There shall pass with the ownership of each Unit as a part hereof, whether or not separately described, all appurtenances to such Unit, including the Common Elements. No part of the appurtenant interest of any Unit may be sold, transferred or otherwise disposed of except in connection with the sale, transfer or other disposition of such Unit itself or of all Units in the Condominium Regime.

**Section 3.** Appurtenances - Funds and Liabilities of Association. There shall be appurtenant to each Unit, and the ownership thereof, an undivided percentage interest of ownership in or liability for the funds and surplus, if any, of the Association, and the common expenses and liabilities of the Association.

**Section 4.** Undivided Ownership Interest. An undivided tenant in common interest in the Land and other Common Elements of the Condominium Regime, regardless of whether such elements are General or Limited Common Elements, shall be appurtenant to each Unit. The amount of such undivided interest appurtenant to each Unit shall be a fraction, the numerator of which is one (1) and the denominator of which is the number of all Units which have been submitted to the Condominium Regime, all as allocated in Exhibit "D". The undivided fractional ownership interest in the Common Elements corresponding to any Unit shall be deemed conveyed or encumbered with that Unit, even though the legal description in the instrument conveying or encumbering the Unit may refer only to the Unit, or may refer to an incorrect ownership interest in the Common Elements for that Unit. No part of the ownership interest in the Common Elements to any Unit may be transferred separately from the Unit itself.

**Section 5.** No Right of First Refusal. The right of an Owner to sell, transfer or otherwise convey the Owner's Unit will not be subject to any right of first refusal or any similar restriction in favor of the Association.

**Section 6.** Right to Mortgage. Each Owner shall have the right, subject to this Declaration, to grant separate mortgages for the Owner's Unit together with the respective ownership interest in the Common Elements. No Owner shall have the right or authority to make or create or cause to be made or created any mortgage or other lien on or affecting the Condominium Property or any part hereof, except only to the extent of such Owner's Unit and the respective ownership interest in the Common Elements appurtenant thereto.



**Section 7.** Use of General Common Elements. Appurtenant to each Unit shall be a right to use and enjoy the General Common Elements subject to rules and regulations established by the Association.

**Section 8.** Use of Limited Common Elements. The exclusive use of Limited Common Elements shall be deemed an appurtenance of the Unit or Units for which such elements are reserved provided such use and enjoyment shall be limited to the uses permitted by this Declaration or by the Association. The reservation of the Limited Common Elements shall not limit any right of the Board of Directors to alter such Limited Common Elements or enter upon such Limited Common Elements. At the time of conveyance, each respective document of conveyance shall be deemed to convey the Limited Common Elements to be used exclusively in conjunction with the respective Unit without necessity of naming the same.

#### **ARTICLE IV MEMBERSHIP AND VOTING RIGHTS IN THE ASSOCIATION**

**Section 1.** Membership and Voting. Appurtenant to each Unit shall be membership in the Association and one vote in the affairs of the Association, provided the exercise of such membership rights and voting shall be subject to the applicable provisions of this Declaration and the Bylaws. Copies of the Articles of Incorporation and Bylaws are attached hereto as Exhibit "E", and by this reference are incorporated herein and made a part of this Declaration, the same as if they were fully set forth herein and the Owners are bound thereby. When more than one Person holds an interest in any Unit, all such Persons shall be Members. Ownership of a Unit shall be the sole qualification for membership. When more than one Person holds an interest in any Unit, the vote for such Unit shall be exercised as they among themselves determine, but in no event shall more than one vote be cast with respect to any one Unit.

**Section 2.** Voting Rights. Whenever a vote or other action of the Members as a group is required, the mechanics of conducting such vote or taking such action shall be under the control and supervision of the Association. The action of the Association shall be deemed the action of the Owners or of the Council of Co-Owners whenever such action is permitted or required by Chapter 499B, Code of Iowa; and such action when taken in accordance with the Bylaws and this Declaration shall be final and conclusive upon all Owners.

#### **ARTICLE V MANAGEMENT OF THE CONDOMINIUM REGIME**

**Section 1.** Association Authority and Obligations. The business and affairs of the Condominium Regime shall be governed and managed by the Association, which corporation is and shall constitute a Council of Co-Owners for all of Condominium Regime. The Association, through its Board of Directors, shall have the right, power and authority to provide for the enforcement of this Declaration; to have sole control and jurisdiction over the Condominium Property; to be responsible to operate, maintain and keep the same in good, clean, attractive and sanitary condition, order and repair in compliance with the standards of sound property management; to establish, levy, collect, and have jurisdiction, control and possession of





assessments for common expenses as hereinafter provided; to enter into contracts as may be necessary or desirable to carry out the provisions of this Declaration; and to otherwise establish such rules and regulations governing use of the Condominium Property which are in the best interests of the Condominium Regime.

**Section 2.** Implied Rights. The Association may exercise any right or privilege given to it expressly by this Declaration, the Articles, the Bylaws or reasonably implied from or reasonably necessary to effectuate any such right or privilege. Except as otherwise specifically provided in this Declaration, the Articles, the Bylaws or by applicable law, all rights and powers of the Association may be exercised by the Board of Directors at its discretion without a vote of the Members.

**Section 3.** Designation of Board of Directors. Declarant shall have the right to name all members of the Board of Directors until Declarant no longer owns any Unit in the Condominium Regime or until Declarant waives, in writing, its right to name all Directors. Thereafter the Board of Directors shall be selected in the manner specified in the Bylaws. Each Owner by acceptance of a deed shall be deemed to have released Declarant from all claims with respect to actions taken or not taken while Declarant controls the Association. In addition to any right, power or privilege authorized hereinafter, the Board of Directors shall manage the affairs and business of the Association.

**Section 4.** Powers; Foreclosure of Lien; Waiver of Partition. Each Owner agrees that the Association has and shall exercise all powers, rights and authority granted unto it under Chapters 504 and 499B Code of Iowa, and such as are more particularly set forth in this Declaration and the Bylaws; including, the right to make assessments for common expenses chargeable to each Owner and the creation of a lien encumbering the Units, and the right, acting on behalf of the Owners, to foreclose on said liens. All Owners shall be deemed to have waived all rights of partition, if any, in connection with such acquisition. Each Owner hereby waives any right to delay or prevent such foreclosure by the Association which such Owner may have by reason of a homestead exemption.

**Section 5.** Limitation of Association's Liability. The Association shall not be liable for any failure of water or other service to be obtained and paid for by the Association hereunder, or for injury or damage to property caused by or on the Common Elements or by another Owner or Person in the Condominium Regime, or resulting from electricity, water, rain, air, dust, dirt or sand which may leak or flow from outside or from any parts of the Building, or from any of its pipes, drains, conduits, appliances or equipment or from any other place unless caused by negligence of the Association. No diminution or abatement of common expense assessments shall be claimed or allowed for inconveniences or discomfort arising from the making of repairs or improvements to the Common Elements or from any action taken to comply with any law, ordinance or orders of a governmental authority.

**Section 6.** Indemnification. Each Member of the Association shall be indemnified by the Owners against all expenses and liabilities, including attorney's fees, reasonably incurred or imposed upon the Member in connection with any proceedings to which the Member may be a party, or in which the Member may become involved, by reason of the Member being or having



been an officer or director of the Association or any settlement thereof, whether or not the Member is an officer or director at the time such expenses are incurred, except in such cases wherein such Person is adjudged guilty of or liable for willful misfeasance or malfeasance in the performance of the member's duties; provided that in the event of a settlement the indemnification shall apply only when the Board of Directors approves such settlement and reimbursement as being for the best interest of the Association and Condominium Regime.

**Section 7.** Duration. No dissolution of the Association shall occur unless another association or equivalent entity has been created to succeed to the duties and responsibilities of the Association under this Declaration, or unless the Condominium Property is removed from the provisions of the Act as provided in the Act.

**Section 8.** Agreements and Compliance. All Owners, the Association, tenants, families, guests and other Persons using or occupying the Condominium Regime shall be bound by and strictly comply with the provisions of the Bylaws and applicable provisions of this Declaration, and all agreements, regulations, and determinations lawfully made by the Association and its directors, officers or agents shall be binding on all such Owners and other Persons. A failure by any Owner, the Association, tenant, family, guest or other Person occupying or managing the Condominium Regime to comply with the Bylaws or the provisions of this Declaration or any agreement or determination thus lawfully made shall be grounds for an action to recover sums due for damages on the part of the Association or any Owner as applicable and for mandatory or other injunctive relief without waiving either remedy.

**Section 9.** Availability of Documents and Records. The Association shall make available to Owners, lenders and the holders and insurers of the first mortgage on any Unit current copies of this Declaration, the Bylaws and any rules or regulations passed by the Association governing the Condominium Regime and other books, records and financial statements of the Association. Such information shall also be made available by the Association to prospective purchasers of Units, including the most recent audited financial statement of the Association, if such is prepared.

**Section 10.** Management Contract. The Association may enter into a contract for the professional management of its affairs, and the management fee thereof shall become a part of the common expenses.

## **ARTICLE VI ASSESSMENT FOR COMMON EXPENSES**

**Section 1.** Assessments. Each Owner, by acceptance of a deed to a Unit, whether or not it shall be so expressed in such deed, is deemed to covenant and agree to pay to the Association regular assessments payable in monthly installments for such Owner's proportionate share of the common expenses and liabilities of the Association corresponding to that Owner's undivided fractional ownership interest in the Common Elements as allocated in Exhibit "D". The assessments, together with interest, costs and reasonable attorney's fees, shall be a charge on the Unit and shall be a continuing lien upon the Unit against which each assessment is made senior to all liens except a first mortgage of record and any ad valorem taxes. Each assessment, together



with interest, costs and reasonable attorney's fees, shall also be the personal obligation of the Person who was the Owner of the Unit at the time when the assessment became due. The personal obligation for delinquent assessments shall not pass to the Owner's successors in title unless expressly assumed by such successor. The liability of an Owner for all assessments made by the Association may not be avoided by waiver of the use or enjoyment of any Common Element or by abandonment of a Unit.

**Section 2. Purpose of Assessments.** The assessments levied by the Association shall be used exclusively to promote the health, safety and welfare of the residents of the Units; for carrying out the general duties and powers of the Association, including, but not limited to, decoration, operation, management, improvement, maintenance, repair, reconstruction, restoration, replacement, removal and preservation of the Common Elements; for payment of insurance and any other charges agreed upon by the Owners as being a common expense. In making such assessments, the amount to be levied shall be equal and limited to the actual cost to the Association of providing those functions and services set forth in this Declaration.

**Section 3. Maximum Regular Assessment.** The Board of Directors shall establish the maximum regular assessment for common expenses and liabilities of the Association to be assessed against each Unit, which assessment shall include a pro rata portion of the amount of insurance premiums payable by the Association. Any proposed increase of more than thirty percent (30%) greater than the regular assessment levied for the previous year shall require the consent of seventy-five percent (75%) of the Owners who are voting in person or by proxy at a meeting duly called for this purpose. Written notice of the regular assessment, special assessments and such other assessment notices as the Board of Directors shall deem appropriate shall be sent to every Owner subject thereto.

**Section 4. Reserve Fund.** A portion of the regular assessment shall be set aside or otherwise allocated in a reserve fund for the purpose of providing repair and replacement of the Common Elements and any capital improvements which the Association is required to maintain.

**Section 5. Special Assessments for Capital Improvements and Operating Deficits.** In addition to the regular assessment authorized above, the Association may levy, in any assessment year, a special assessment applicable to that year only for the purpose of defraying, in whole or in part, the cost of any construction, reconstruction, repair or replacement of a capital improvement for any Common Element, including fixtures and personal property related thereto which the Association is required to maintain, or for operating deficits that the Association may from time to time incur, provided that any such assessment shall have the assent of seventy-five percent (75%) of the Owners who are voting in person or by proxy at a meeting duly called for this purpose.

**Section 6. Real Estate Tax Assessments.** Taxes, assessments and other charges of any taxing or assessing authority shall be separately assessed and levied against each Unit pursuant to such Owner's corresponding ownership interest in the Common Elements, as provided in the Act. In the event that any such taxes or assessments for any year are not separately assessed and levied against each Owner, but rather are assessed or levied against the Condominium Property as a whole, then each Owner shall pay the Owner's proportionate share thereof in accordance with the Owner's respective ownership interest in the Common Elements, and, in said event, such taxes or



assessments shall be a common expense. Without limiting the authority of the Board of Directors provided for elsewhere herein, the Directors shall have the authority to collect from the Owners their proportionate share of such taxes or assessments for any year in which taxes are assessed or levied against the Condominium Property as a whole, in the same manner as collection for assessments for common expenses.

**Section 7. Date of Commencement of Regular Assessments; Payment of Assessments; Due Dates.** The regular assessments provided for herein shall commence as to each respective Unit on the first day of the first month following the date of conveyance to an Owner of a completed Unit constructed on the Land. The maintenance responsibilities of the Association as to each Unit shall commence concurrently with the commencement of monthly assessments. The regular and special assessments for each Unit conveyed by Declarant to a third party shall become the obligation of the new Owner upon transfer of the Unit. The new Owner shall then begin making payments of regular and special assessments when the next monthly installment is due for such Unit. Thereafter, the monthly installments of regular and special assessments paid to the Association shall be prorated and credited to the Owner in the closing upon the sale or transfer of the Unit by the Owner. The Board of Directors shall establish the due dates for all assessments. All payments shall be made on or before the due date.

**Section 8. Effect of Nonpayment of Assessments; Remedies of the Association.** Any assessment not paid within thirty (30) days after the due date shall bear interest from the due date at the rate of 15% per annum or at the highest rate allowed by Iowa law, whichever is lower. The Association may bring an action at law against the Owner personally obligated to pay the same, or foreclose the lien against the Unit in the manner provided for foreclosure of a mortgage, or both, and there shall be added to the amount of said assessment all costs and expenses incurred by the Association in collecting said assessments, including reasonable attorney's fees, whether or not legal action is required in connection therewith.

**Section 9. Declarant's Non-Liability for Assessments.** Declarant, and the Units which Declarant owns, shall not be liable for any assessments made by the Association whether regular or special.

**Section 10. Subordination of Assessment Liens.** The lien of the assessments provided for herein shall be subordinate to the lien of any first mortgage. The assessment shall be paid prior to or at the closing of sale or transfer of any Unit. However, the sale or transfer of any Unit pursuant to mortgage foreclosure or any proceeding in sale or transfer shall relieve such Unit from liability for any assessments thereafter becoming due or from the lien thereof. Provided, however, the sale or transfer of any Unit pursuant to the foreclosure of any first mortgage on such Unit (without the necessity of joining the Association in any such foreclosure action) or any proceedings or deed in lieu thereof shall extinguish the lien of all assessments becoming due prior to the date of such sale or transfer.



**Section 11. Assessment Certificate.** The Association shall, upon demand, and for a reasonable charge, furnish a certificate in a recordable form setting forth whether the assessments on a specified Unit have been paid. A properly executed certificate from the Association regarding the status of assessments on a Unit shall be binding upon the Association as of the date of its issuance.

## **ARTICLE VII FIRST LIEN HOLDERS RIGHTS**

**Section 1. Notices of Action.** A holder, insurer, or guarantor of a first mortgage, upon written request to the Owner (such request to state the name and address of such holder, insurer, or guarantor and the Unit number), will be entitled to timely written notice of:

- (a) Any proposed amendment of the condominium instruments effecting a change in (i) the boundaries of any Unit or the exclusive easement rights appertaining thereto, (ii) the interest in the General Common Elements appertaining to any Unit or the liability for common expenses appertaining thereto, or (iii) the purposes to which any Unit or the General Common Elements are restricted.
- (b) Any proposed termination of the Condominium Regime;
- (c) Any condemnation loss or any casualty loss which affects a material portion of the Condominium Regime or which affects any Unit on which there is a first mortgage held, insured, or guaranteed by such eligible holder; and
- (d) Any delinquency in the payment of assessments for common expenses or charges owed by an Owner of a Unit subject to the mortgage of such eligible holder, insurer, or guarantor, where such delinquency has continued for a period of sixty (60) days.

## **ARTICLE VIII MAINTENANCE, ALTERATION AND IMPROVEMENTS**

**Section 1. Maintenance by Association.** The Association shall provide and perform all services on behalf of the Owners for operation, improvement, maintenance, repair, reconstruction, restoration, replacement, removal and preservation of all Common Elements of this Condominium Regime as a common expense, unless such responsibility is otherwise imposed by the Association on the Owner in connection with a Limited Common Element. Incidental damage caused to a Unit through maintenance by the Association shall be repaired by the Association as a common expense. If an Owner defaults in the Owner's responsibilities of maintenance, the Association shall assume such as a common expense and levy a special assessment against the Unit collectible from the Owner as other assessments for common expenses. The Association may, in its discretion, assume responsibility for any maintenance project which requires work to more than one Unit and the cost thereof may be in the discretion of the Association either assessed against each Unit on which such costs were incurred or assessed against all Units as a common expense according to the circumstances.



**Section 2.** Maintenance of Storm Water Detention Facilities. Declarant shall be responsible only for the initial installation and construction of the Storm Water Detention Facilities. Upon completion of the initial construction, the Association, at its expense, shall be responsible for all maintenance, repair and replacement of the Storm Water Detention Facilities. Such maintenance obligations shall include, but are not limited to, reconstruction, repair, replacement, inspection, grading, dredging, mowing, replacement of permitted vegetation, removal of trash, litter and debris and any other duties required to be performed for maintenance under any storm water management plan on file with the City. Nothing shall be altered in, constructed in, or removed from the Storm Water Detention Facilities, except upon written consent of the Board of Directors.

**Section 3.** Landscaping. The Association shall have sole control over the Land, and the trees, shrubs, landscape plantings, retaining wall structures or other stabilization plantings and decorative features within the Land. The Board of Directors shall have the right to change the plantings and other landscaping elements within the Land from time to time in its sole discretion subject to plantings allowed or required pursuant to any landscaping plan on file with the City or under a recorded easement for buffering or storm water detention management.

**Section 4.** Responsibility for Willful or Negligent Acts. No Owner shall obstruct or interfere whatever with the duties and responsibilities of the Association to perform its maintenance obligations relating to the Common Elements. An Owner shall be liable to the Association for the expense of any maintenance, repair or replacement to the Common Elements rendered necessary by any intentional, willful, negligent or careless act of such Owner or by that of family, guests, tenants or licensees of such Owner. Any such expense for maintenance, repair or replacement shall be added to and become a part of the common expenses to which such Unit is subject.

**Section 5.** Maintenance by Owner. Each Owner shall furnish and be responsible for, at the Owner's own expense, all decoration, maintenance, repair and replacement of the structures, improvements, fixtures and equipment located upon and within the Owner's Unit. All Units and property appurtenant thereto shall be kept in a safe, clean, orderly and sanitary environment free of insects, rodents, vermin and other pests and maintained in a good condition and state of repair at all times. The Owner, at such Owner's own expense, shall be responsible to provide all maintenance of the Unit, which includes, but is not limited to of the following:

- (a) Garage door, and all other doors and windows, including trim and any exterior brickmold or siding damaged by replacement;
- (b) Non-load bearing partition and interior surfaces of walls and ceilings, drywall and trim;
- (c) Fireplaces, electronics, appliances, plumbing equipment and fixtures, heating, ventilation and air conditioning, and security system;



- (d) Staircases, cabinetry, bookcases and counter tops;
- (e) Interior wall coverings, floor coverings and window treatments;
- (f) Interior and exterior electrical wiring and facilities and light fixtures, including light bulb replacement in exterior light fixtures, for the exclusive use of the Unit;
- (g) Electrical lines for telecommunication and electrical facilities from the main box to a Unit, notwithstanding the fact that such wiring crosses or is located off-premises from the Owner's Unit.
- (h) Removal of snow, ice and debris from patios, decks and stoops;
- (i) Flowers, plantings, gardens, shrubbery and other landscaping planted by the Owner and approved by the Association;
- (j) Tower, antenna, satellite dish or similar reception devices installed by the Owner, including roof shingles and any exterior surface of the Building damaged by replacement or removal;
- (k) Any improvement or other alteration subsequently added to the Unit by the Owner; and
- (l) Owners shall promptly report to the Association any defects or other maintenance needs which are the responsibility of the Association.

**Section 6. Utilities.** Each Unit Owner shall pay all charges before they become delinquent for electricity, water, trash removal, gas, sewer, telephone, telecommunications, cable, television and any other similar utility service which is billed directly to the Unit Owner.

**Section 7. Shared Facilities, Equipment and Fixtures.** To the extent that facilities, equipment and fixtures within the Condominium Regime shall be connected to similar facilities, equipment or fixtures affecting or serving more than one Unit, then the use thereof shall be subject to the rules and regulations of the Association.

**Section 8. Discharge of Liability.** Each Owner shall promptly discharge any lien, which may hereafter be filed against the Unit.

**Section 9. Alteration or Improvements by Owner.** No Owner shall make any structural alteration to a Unit or to the Building or any of the Common Elements, without first obtaining approval of the Board of Directors as to the proper insurance of such alterations or improvements under any master insurance policy purchased by the Association or by an insurance policy purchase by the Owner and as to arrangements for bearing the expense of such insurance. In addition, no such alteration or improvement shall be made unless approved by the Board of Directors and no work by an owner is permitted which will jeopardize the soundness of the





Building or impair any easement. Any alteration or improvement of a Unit shall neither increase nor decrease the ownership interest in the Common Elements appurtenant to that Unit. Any alteration or improvement of a Unit must be coordinated with the Board of Directors before proceeding.

**Section 10.** Alteration or Improvements by the Association. Whenever in the judgement of the Board of Directors the Common Elements shall require addition, alterations or improvements during the fiscal year costing in the aggregate in excess of \$5,000.00, and the making of such additions, alterations or improvements shall have been approved by majority vote of the Units, the Board of Directors shall proceed with such additions, alterations or improvements and shall assess all Owners for the cost thereof as a common expense. Any additions, alterations, or improvements during the fiscal year costing in the aggregate \$5,000.00 or less may be made by the Board of Directors without approval of the Owners, and the cost thereof shall constitute part of the common expenses.

## **ARTICLE IX INSURANCE AND FIDELITY BONDS**

**Section 1.** Casualty Insurance. The Association shall obtain and maintain at all times, comprehensive general liability insurance coverage covering all of the Common Elements and any public areas of the Condominium Property. Coverage limits shall be in amounts generally required by private institutional mortgage investors for projects similar in construction, location and use. Coverage under this policy shall include, without limitation, legal liability of the insureds for property damage, bodily injuries and deaths of persons in connection with the operation, maintenance or use of the Common Elements.

**Section 2.** Liability Insurance. The Association shall also purchase such other policies of insurance including insurance for other risks of a similar or dissimilar nature as are or shall hereinafter be considered appropriate by the Association, including fidelity bonds insuring the acts of members of the Board of Directors, if such Directors deem such fidelity bonds to be necessary or appropriate.

**Section 3.** Assessment for Insurance. The premiums for the insurance coverage above shall be paid by the Association and the costs of the same shall be a common expense. The Association is authorized to provide coverage for payment of maintenance charges which are abated hereunder on behalf of an Owner whose Unit is rendered uninhabitable for a peril insured against.

**Section 4.** Distribution to Mortgagee. In no event shall any distribution of proceeds be made by the Board of Directors directly to an Owner where there is a mortgagee endorsement on the certificate of insurance. In such event, any remittances shall be to the Owner and the mortgagee jointly, or in accordance with the terms of any endorsement in favor of the mortgagee.





**Section 5.** Annual Review of Policies. The Board of Directors shall review at least annually all insurance policies acquired by the Association for the amount and type of such insurance and shall purchase such additional insurance as is necessary to provide the insurance required above.

**Section 6.** Owner's Insurance. Each Owner, at such Owner's expense, shall obtain a liability and casualty insurance for personal property, fixtures, and all other property that is not covered by the insurance maintained by the Association.

**Section 7.** Casualty and Restoration. Damage to or destruction of a Building or other improvement due to fire or any other casualty or disaster which causes damage or destruction to all or part of the Condominium Property shall be promptly repaired and reconstructed by the Association using the proceeds of insurance on the same for that purpose, and all of the Owners shall be liable for assessment for any deficiency in proportion to their respective ownership interest in the Common Elements. For purposes of this Section, repair, reconstruction and restoration shall mean the restoring of the same to substantially the same condition as was authorized by the Association and existing prior to the damage or destruction, with each Unit and the Common Elements having the same vertical and horizontal boundaries as before.

**Section 8.** Insufficiency of Insurance Proceeds. If the insurance proceeds received by the Association as a result of any fire or any other casualty or disaster are not adequate to cover the cost of repair and reconstruction, or in the event there are no insurance proceeds, the cost for restoring the damage and repairing and reconstructing the a Building so damaged or destroyed (or the costs thereof in excess of insurance proceeds received, if any) shall be paid by the Association, which shall then have the right to levy a special assessment against all Units for the amount of such deficiency.

**Section 9.** Surplus of Insurance Proceeds. If there is any surplus of insurance proceeds after reconstruction or repair of the damage has been fully completed and all costs paid, such sums may be retained by the Association as a reserve or may be used in the maintenance and operation of the Common Elements, or, in the discretion of the Board of Directors, may be distributed to the Owners of the Building affected and their mortgagees who are the beneficial owners of the fund. The action of the Board of Directors in proceeding to repair or reconstruct damages shall not constitute a waiver of any rights against Owner for committing willful or malicious damage.

## **ARTICLE XI EASEMENTS**

**Section 1.** Encroachment Easements. If any portion of the Common Elements encroaches upon any Unit, or if any Unit encroaches upon any other Unit or upon any portion of the Common Elements, or if any of such encroachments shall occur hereafter as a result of shifting or settling of the Building or from alteration, repair or improvement to the Common Elements or as a result of repair or restoration of the Common Elements or a Unit after damage by fire or other casualty, or as a result of condemnation or of eminent domain proceedings, then in each of such events a valid easement shall exist for such encroachment and for the maintenance thereof so long



as the Building, Common Elements and Units exist.

**Section 2. Cross Easements.** Appurtenant to each Unit shall be easements from each Owner to each other Owner and to the Association and from the Association to the respective Owners as follows:

- (a) For ingress and egress through the Common Elements for access to the Units for maintenance, repair, replacement or reconstruction of the Units as authorized, including, without limitation, paved driveways.
- (b) For ingress and egress through the Units and Common Elements for maintenance, repair, replacement or reconstruction of the Common Elements and license to use hoses, bibs and water from all Units to perform such maintenance obligations. Agents of or contractors hired by Declarant or the Board of Directors may enter the Common Elements when necessary in connection with any maintenance, landscaping, or construction for which the Association is responsible, provided such entry shall be made with as little inconvenience to the Owners as practicable.
- (c) For ingress and egress through the Common Elements and through the attic and basement of any Building thereon to access conduits, ducts, plumbing, wiring, pipes, and other facilities for the furnishing of utilities, heating and air conditioning systems and similar services to other Units, and for foundation drains, sanitary sewer and water service facilities, including the location of utility meters and equipment in one Unit for service to another Unit.
- (d) Each Unit is burdened with an easement for sidewalks for use by pedestrians and non-motorized vehicles to obtain access from the public or private street and from one property to another.
- (e) Every portion of a Unit contributing to the support of the Building is burdened with an easement of support for the benefit of all other Units and the Common Elements.

**Section 3. Utility Easements.** The Association shall have the right to grant utility easements under, through and over the Common Elements, which are reasonably necessary to the ongoing development and operation of the Condominium Property.

**Section 4. Easement for Emergency Purposes.** An easement is hereby dedicated and granted for ingress, egress and parking in case of emergency by emergency vehicles such as fire trucks, police cars and ambulances and emergency personal, public and private, over and upon the Condominium Property. Officers, employees or contracted agents of any governmental agency shall have the right and authority to enter upon the common area for the administration of public services including fire protection, law enforcement, water service and animal control. The rights encompassed within this grant shall include the right to use all entrances, exits, sidewalks, driveways and similar facilities that may now or hereinafter be established and constructed upon any portion of the Condominium Property.



**Section 5.** Parking Rights. The paved driveway in front of each Owner's garage shall be for the exclusive use of such Owner and any family, guest, tenant or licensee of such Owner. No Owner, family member, tenant, guest or invitee shall block vehicular access to garages, driveways, garage units or parking spaces. No vehicles shall be permanently parked on unreserved parking spaces or any driveway in the Condominium Regime. The Association may by regulation or rule limit or prohibit guest parking or the parking of vehicles on the parking areas and private streets.

## ARTICLE XII USE RESTRICTIONS

**Section 1.** Subjection of the Condominium Property to Certain Provisions. The ownership, use, occupation and enjoyment of each Unit and the Common Elements shall be subject to the provisions of the Bylaws and this Declaration, all of which provisions irrespective of where set forth or classified shall have equal status and shall be enforceable and binding as a covenant, condition, restriction or requirement running with the land and shall be binding on and enforceable against each and all Units and the Owners thereof and their respective assigns, lessees, tenants, occupants and successors in interest.

**Section 2.** Designation of Use. All Units shall be improved, used or occupied for single-family dwelling purposes only. No full or part-time business activity may be conducted in any Unit except those activities permitted under the terms of the zoning ordinance of the City.

**Section 3.** Rental Regulations. In order to protect the integrity of the Condominium Regime and to ensure that those Persons residing therein have similar proprietary interests in their Units, all leases shall be in writing and shall be provided to the Association prior to occupancy. All leases shall acknowledge the tenant's responsibilities under this Declaration. No lease shall relieve the Owner of the Unit from liabilities and responsibilities to the Association and other Owners as set forth in this Declaration or imposed under the laws of the State of Iowa.

**Section 4.** Rules and Regulations. The Association shall have the authority to amend and adopt reasonable rules and regulations governing the use of the Condominium Property and such rules shall be observed and obeyed by the Owners, their guests, and licensees. Such rules after being properly adopted shall have the same force and effect as if contained in this Declaration.

**Section 5.** General Use Restrictions. The use of the Units shall be in accordance with and subject to the following provisions:

- (a) No structure, trailer, camper, basement, tent, shack, garage, shed, or other building shall be used on the Condominium Property at any time as a residence, either temporarily or permanently.
- (b) No fence shall be allowed to be constructed on any Lot without prior approval from the Board of Directors. Any fence approved by the Board of Directors shall be limited to privacy or decorative fences located around the decks or patios of the Units.



- (c) No livestock, poultry, or other animals of any kind shall be raised, bred or kept in any Unit, except an Owner shall be permitted to keep cats, dogs, or other usual household pets subject to rules and regulations adopted by the Association, based on the City Pet Ordinance. No exotic, dangerous or vicious animals shall be allowed. No dogs or cats shall be permitted outside of the Unit unless leashed and attended by the Owner. Pets shall be registered, licensed and inoculated as required by law. No dog runs, doghouses, animal pens, sheds, fences or other outbuilding or structure of any kind, or unattended chains or invisible fencing shall be permitted. The Owner shall be responsible for prompt removal and disposal of all waste from their pets. No Owner may house more than two (2) pets within the Unit. The Association may, by rules and regulations, prohibit or further limit the keeping of any pet on any Unit, provide for assessments to Units housing pets, or provide penalties for Owners found in violation of this Section or the rules and regulations regarding pets.
- (d) No noxious or offensive activity shall be allowed which unduly interferes with the peaceful possession and use of the Units by the Owners; nor shall any fire hazard or unsightly accumulation and refuse be allowed; nor shall any Unit be used for any unlawful purpose.
- (e) Nothing shall be done or kept in any Unit or in the common area which will increase the rate of insurance on the Condominium Regime without prior consent of the Board of Directors. No Owner shall permit anything to be done or kept in the Owner's Unit or in the common area which will result in the cancellation of insurance on any Unit or any part of the common area or the Common Elements, which would be in violation of any law, or which may be or become a nuisance or annoyance to the other Owners.
- (f) All valid laws, zoning ordinances, and regulations of all governmental bodies having jurisdiction shall be observed. The responsibility of meeting the requirements of governmental bodies which require maintenance modification or repair of property shall be the same as the responsibility for the maintenance and repair of the property concerned.
- (g) Trash receptacles shall be kept by Owners within the garage of the Unit and shall be set outside only at the end of the driveway serving the Unit on designated garbage pick-up days.
- (h) No tower, antennae, satellite dish or similar reception device shall be placed on any Building or common area except those which cannot be prohibited pursuant to the Federal Over-the-Air Reception Devices Rule, 47 C.F.R. §1.4000, or other similar governmental mandate in effect at the time of placement. All installations shall be completed so as not to materially harm or damage the Common Elements; or to void any warranties held by the Association; or to jeopardize or impair the integrity, safety or soundness of the Building. Upon receipt of reasonable notice, an Owner shall remove and reinstall, at such Owner's sole expense, the reception device to accommodate repairs and maintenance for which the Association is responsible. The Owner shall be responsible to the Association for any expense, liability, or damage of



any kind resulting from the installation, maintenance, and use of the tower, antenna, satellite dish or similar reception device. The Association will not be responsible to an Owner for any loss or damage to any tower, antenna, satellite dish or similar reception device.

- (i) No basketball goal, whether attached to the Unit or affixed to a free-standing pole, soccer goal, baseball backstop or other similar sporting equipment shall be allowed to be constructed without prior approval from the Board of Directors.
- (j) No personal property shall be stored or left upon the Condominium Property except within the Unit or garage. However, unattached sporting equipment, toys, outdoor cooking equipment, and other equipment and supplies necessary or convenient to residential living may be stored on the patio or deck of the Unit.
- (k) Garage doors shall be kept closed except during times of access to the garage or as permitted by the rules and regulations of the Association.
- (w) Complaints regarding the services of the Building shall be made in writing to the Board of Directors or to the managing agent or the manager of the Association.

### **ARTICLE XIII GENERAL PROVISIONS**

**Section 1.** Enforcement. Declarant, the Association, or any Owner, shall have the right to enforce, by any proceeding at law or in equity, all restrictions, conditions, covenants, reservations, liens, assessments, fines, and charges now or hereafter imposed by the provisions of this Declaration, and shall be entitled to recover reasonable attorney's fees and costs and expenses incurred as a result thereof.

**Section 2.** No Waiver. Failure by the Association, or by any Owner to enforce any covenant or restriction herein contained or the Bylaws, or the rules and regulations adopted pursuant thereto, shall not constitute a waiver of the right to enforce the same thereafter.

**Section 3.** Notice to Mortgagees. The Association, upon request, shall provide written notification to any lender holding a first mortgage upon any Unit specifying the defaults of the Owner of such Unit, if any, in the performance of such Owner's obligations under this Declaration, the Bylaws, or any other applicable documents which default has not been cured within sixty (60) days.

**Section 4.** Severability. The invalidity of any one or more phrases, sentences, clauses, paragraphs, Sections or Articles hereof shall not affect the remaining portions of this Declaration or any part thereof, all of which are inserted conditionally on their being valid in law and in the event that one or more phrases, sentences, clauses, paragraphs, Sections or Articles contained herein should be invalid or should operate to render this Declaration invalid, this Declaration shall be construed as if such invalid phrase, sentence, clause, paragraph Section or Article have not been inserted, and shall in no way effect any of the other provisions which shall remain in full force and



effect.

**Section 5. Limitation of Liability.** Declarant shall not be liable to the Association or any Owner for losses, damages or repairs relating to:

- (a) Any private street, sidewalk, driveway, curb, stoop, patio or other concrete improvement located within the Condominium Property, including (but not limited to) cracking or chipping that may occur due to weather conditions.
- (b) Any appliance, including, but not limited to, the furnace, air-conditioner, stove, oven, dishwasher and garbage disposal, beyond the express warranties set forth in the manufacturer's warranty provided to the original owner.
- (c) Any security system failure or ineffectiveness of any security measures undertaken or not undertaken in the Condominium Property.

**Section 6. Duration.** The easements granted herein, and all Association rights, duties, obligations and responsibilities shall be perpetual in nature. All covenants, conditions, restrictions, easements and reservations created by this Declaration shall run with the land and shall be binding upon all parties claiming under them for the maximum period allowed by law, subject to the right of Owners under Section 614.24 of the Iowa Code to file a verified claim in the office of the County Recorder to extend the effectiveness of these covenants for successive periods of twenty-one (21) years each on or before the twenty-first anniversary of the filing of this Declaration and prior to the twenty-first anniversary of the filing of the last verified claim. Invalidation of any of the covenants, conditions, restrictions, easements or reservations of this Declaration by judgment or decree shall in no way effect any of the provisions hereof, but the same shall remain in full force and effect.

**Section 5. Amendment.** This Declaration may be amended or changed from time to time by an instrument filed of record in the office of the County Recorder, signed or approved in writing by the affirmative vote of not less than two-thirds (2/3) of the Owners of Units in the Condominium Regime, provided, however, none of the rights or duties of Declarant or the Association reserved or set out hereunder may be amended or changed without Declarant's or the Association's prior written approval. The Owner of each Unit (or the joint Owners of a single Unit in the aggregate) shall be entitled to cast one vote on account of each Unit owned. Notwithstanding the foregoing, this Declaration may be amended by Declarant without approval by the other Owners, the Association or any other Person so long as Declarant has any ownership interest in the Units. Such amendments or modifications shall be effective the date the amendment or modification has been filed with the County Recorder.

**Section 6. Fractional Ownership Interest.** No amendment or modification to this Declaration shall change the boundaries of any Unit unless done in conjunction with the provisions of this Declaration, nor the means for determining the undivided fractional interest in the Common Elements appurtenant to any Unit, nor the number or weight of votes allocated to any Unit, nor the liability for common expenses appertaining to any Unit. No amendment shall change or affect the provisions of this Section.



**ARTICLE XIII  
DECLARANT'S RESERVATION OF RIGHTS**

**Section 1.** Additional Land. Declarant reserves the irrevocable right in its discretion to create and record any replat or subsequent plat as Declarant deems appropriate and to annex and subject additional land to the terms of this Declaration at any time in the future without the consent of the Owners, the Association, or any other Person. Nothing in this Section, however, shall be deemed to be an obligation on the part of Declarant to annex and subject additional land to the terms of the Declaration in the future. The additional land shall be automatically subject to the applicable terms and conditions of this Declaration and Owners of Units within the additional land shall automatically become Members of the Association in the same manner as described in this Declaration and shall be subject to the same applicable terms, conditions, duties and assessments as described in this Declaration. Declarant shall signify the addition of the additional land by a Supplemental Declaration filed of record with the County Recorder with such terms and conditions as Declarant deems appropriate.

**Section 2.** Marketing of Units. Declarant reserves the right to use any of its Units as models and to sell, assign, or conduct other business in connection with the construction and development of the Condominium Regime from any of the Units prior to their being sold. This reservation of right or privilege in Declarant includes, but is not limited to, the right to maintain model homes, maintain an office, staff the office with employees, display signs, and show any of its Units then unsold. Neither the Owners nor the Association shall interfere with the construction of improvements and sale of the Units by Declarant. Declarant retains the right to be considered an Owner of any Unit that remains unsold.

**Section 3.** Construction of Buildings. Declarant reserves the right to make changes in the number, location, or manner of construction of Buildings, arrangement of the Units, and other improvements; provided, that in all cases, such changes shall be accomplished in a manner consistent with applicable laws and ordinances.

**Section 4.** Variation and Adjustments. Declarant reserves the right to substitute for any of the materials, equipment and appliances, such materials, equipment and appliances of equal or better quality.

**Section 4.** Right of Access. Declarant reserves an easement over the Common Elements for the purpose of completing the improvements thereof contemplated by this Declaration. Provided, however, Declarant shall restore any Common Element disturbed by Declarant's use of such easement to the condition existing prior to the disturbance as soon as practically feasible after Declarant's use of the easement rights granted herein are concluded. Also, the easement rights granted herein shall be exercised by Declarant only if and when the access required by Declarant is not otherwise reasonably available other than over, across or through the Common Elements.





**Section 5.** Assignment of Declarant's Rights. Declarant shall have the right to assign all of its reserved rights and obligations as Declarant to a successor-in-interest by an instrument executed by both parties and filed of record with the County Recorder. Upon such assignment, the initial or preceding Declarant shall have no further rights and obligations in connection with this Declaration, the Association and the Condominium Property.

**Section 6.** Transfer of Declarant's Rights. At the end of the Control Period, all rights, privileges, duties, obligations, responsibilities, reservations and authority of Declarant set forth in this Declaration and the Bylaws shall automatically transfer to the Association. Upon such transfer, Declarant shall have no further rights and obligations in connection with this Declaration, the Association and the Condominium Property.

IN WITNESS WHEREOF, the undersigned has caused this Declaration to be executed this 22 day of June, 2020.

GROUND BREAKER HOMES, LLC,  
an Iowa limited liability company

By: Steve Bruere  
Steve Bruere, Manager

STATE OF IOWA, COUNTY OF POLK:

This record was acknowledged before me on June 22, 2020, by Steve Bruere, Manager of Ground Breaker Homes, LLC.

By: Kalen Ludwig  
Notary Public



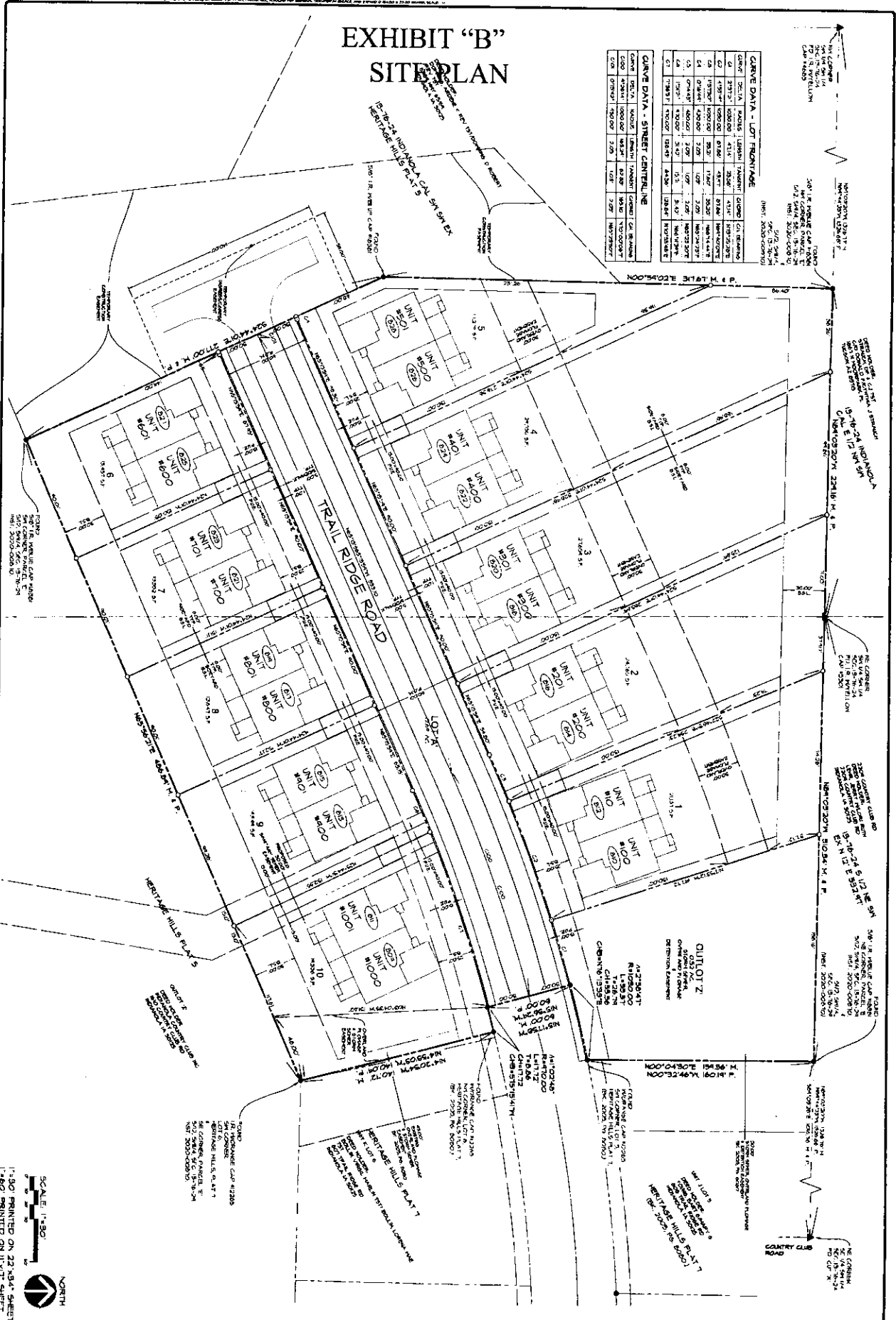

**EXHIBIT "A"**  
**LAND**

Lots 1 – 10 and Outlot Z in HERITAGE HILLS PLAT 10, an Official Plat in Indianola, Warren County, Iowa.



# EXHIBIT "B" SITE PLAN



Curve	Delta	Radius	Length	Chord	Chord Bearing	Stationing
C1	237.73	1000.00	41.14	28.56	41.14	1+00.00
C2	179.73	1000.00	31.88	21.87	31.88	1+100.00
C3	179.73	1000.00	31.88	21.87	31.88	1+200.00
C4	179.73	1000.00	31.88	21.87	31.88	1+300.00
C5	179.73	1000.00	31.88	21.87	31.88	1+400.00
C6	179.73	1000.00	31.88	21.87	31.88	1+500.00
C7	179.73	1000.00	31.88	21.87	31.88	1+600.00

Curve	Delta	Radius	Length	Chord	Chord Bearing	Stationing
C10	45.84	1000.00	8.24	6.28	45.84	1+000.00
C11	45.84	1000.00	8.24	6.28	45.84	1+050.00
C12	45.84	1000.00	8.24	6.28	45.84	1+100.00
C13	45.84	1000.00	8.24	6.28	45.84	1+150.00
C14	45.84	1000.00	8.24	6.28	45.84	1+200.00
C15	45.84	1000.00	8.24	6.28	45.84	1+250.00
C16	45.84	1000.00	8.24	6.28	45.84	1+300.00
C17	45.84	1000.00	8.24	6.28	45.84	1+350.00
C18	45.84	1000.00	8.24	6.28	45.84	1+400.00
C19	45.84	1000.00	8.24	6.28	45.84	1+450.00
C20	45.84	1000.00	8.24	6.28	45.84	1+500.00

SCALE: 1"=30'  
 1"=30' PRINTED ON 22"x34" SHEET  
 1"=30' PRINTED ON 11"x17" SHEET

NORTH

HERITAGE HILLS PLAT 10  
 INDIANOLA, IOWA  
 ADDRESSING SITE PLAN

DATE	REV	NO	COMMENTS
JUNE 14, 2020	1	1	ISSUED FOR PERMITS
	2	2	
	3	3	
	4	4	
DATE OF SURVEY:	10	10	
DESIGNED BY:	10	10	
DRAWN BY:	10	10	

**CEC** Civil Engineering Consultants, Inc.  
 2400 86th Street, Unit 12, Des Moines, Iowa 50322  
 515.276.4884 Fax: 515.276.7084 mail@cecinc.com

**EXHIBIT "C"**  
**FLOOR PLANS FOR ALL UNITS**



**'NEW ERA' TOWNHOMES - PLAT 10**  
**SPEC UNITS W/ SUNROOM**

ADDRESS T.B.D.

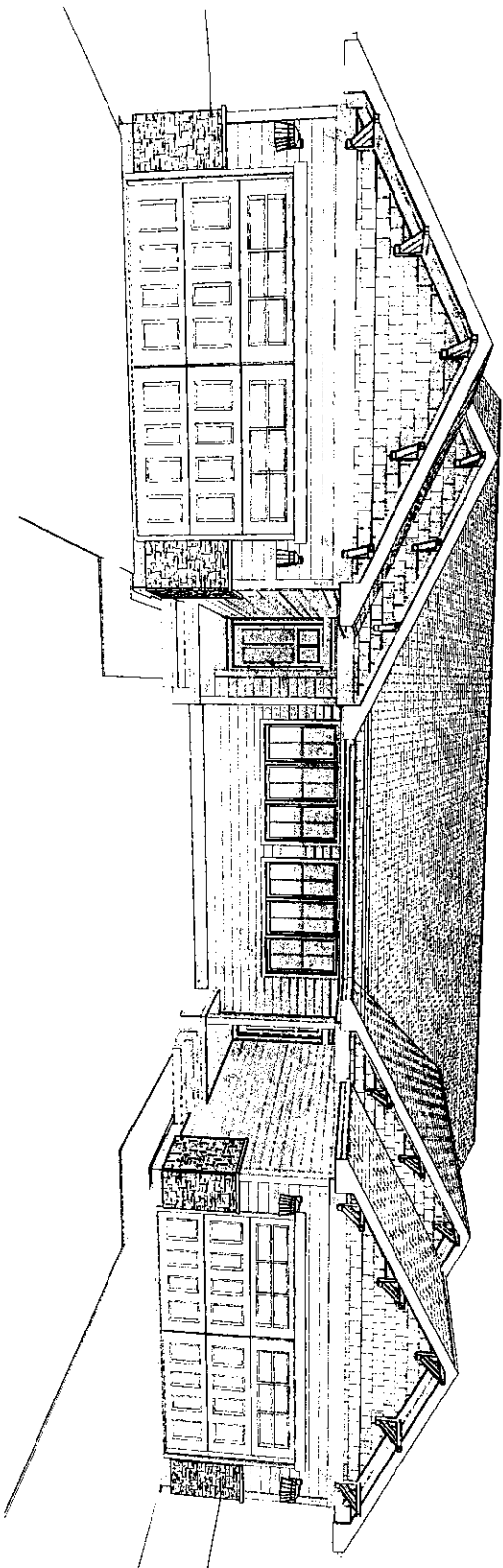

**AREA CHART**

AREA SCHEDULE - FULL BASEMENT W/ SUNROOM			
BASEMENT	SQ. FT.	MAIN FLOOR	SQ. FT.
UTILITY/STORAGE ROOM	497	CONDITIONED LIVING SPACE	1,623
STORAGE UNDER STAIRS	50	GARAGE	590
CONDITIONED LIVING SPACE w/ ORIGINAL FINISHES - BASEMENT	1,040	PORCH DECK	40
			160
TOTAL COND. LIVING SPACE		1,623	
TOTAL UNCOND. SPACE		2,071	
TOTAL COND. LIVING SPACE w/ OPT. FINISHED BASEMENT		2,663	
TOTAL UNCOND. SPACE w/ OPT. FINISHED BASEMENT		1,037	
TOTAL OUTDOOR SPACE		200	

AREA SCHEDULE - WALKOUT BASEMENT W/ SUNROOM			
BASEMENT	SQ. FT.	MAIN FLOOR	SQ. FT.
UTILITY/STORAGE ROOM	497	CONDITIONED LIVING SPACE	1,623
STORAGE UNDER STAIRS	50	GARAGE	590
CONDITIONED LIVING SPACE w/ ORIGINAL FINISHES - BASEMENT	1,072	PORCH DECK	40
			144
TOTAL COND. LIVING SPACE		1,623	
TOTAL UNCOND. SPACE		2,104	
TOTAL COND. LIVING SPACE w/ OPT. FINISHED BASEMENT		2,695	
TOTAL UNCOND. SPACE w/ OPT. FINISHED BASEMENT		1,037	
TOTAL OUTDOOR SPACE		184	

**SHEET INDEX - W/ SUNROOM**

- 61.0 - COVER SHEET, PROJECT INFORMATION, AREA CHART, & SHEET INDEX
- 61.1 - GENERAL NOTES, VIGNETTE PLAN, REVISION TABLE & ABBREVIATIONS
- A1.1 - BASEMENT FOUNDATION PLAN - FULL BASEMENT
- A2.1 - BASEMENT FOUNDATION PLAN - WALKOUT
- A1.2 - MAIN FLOOR PLAN - W/ FULL BASEMENT
- A1.3 - MAIN FLOOR PLAN - WALKOUT BASEMENT
- A2.1 - MOOP PLAN
- A3.1 - EXTERIOR ELEVATIONS - FRONT & REAR - FULL BASEMENT
- A3.2 - EXTERIOR ELEVATIONS - FRONT & REAR - WALKOUT BASEMENT
- A3.3 - EXTERIOR ELEVATIONS - LEFT & RIGHT - FULL BASEMENT
- A3.4 - EXTERIOR ELEVATIONS - LEFT & RIGHT - WALKOUT BASEMENT
- D1 - DETAILS & SECTION SHALL BE INCLUDED IN CONSTRUCTION DOCUMENT SET

**PROJECT INFO**

OWNER: N/A  
 PROJECT ADDRESS: ADDRESS T.B.D.  
 LEGAL: .....  
 CODE ENFORCEMENT: BOB COUNTY, CITY OF BOB  
 WATER: .....  
 PERMIT: .....  
 DESIGNER: RESIDENTIAL - REMODELING DESIGN, LLC  
 BUILDER/ CONTRACTOR: GROUND BREAKER HOMES  
 ENGINEERING: N/A  
 LANDSCAPE DESIGN: N/A

PRICING SET - NOT FOR CONSTRUCTION

DATE: 4/20/20  
 SHEET: 61.0

DRAWINGS PROVIDED BY:  
**RESIDENTIAL REMODELING DESIGN**

COVER SHEET, PROJECT INFORMATION, AREA CHART, & SHEET INDEX

'NEW ERA' TOWNHOMES - PLAT 10  
 ADDRESS T.B.D.

SPEC UNITS W/ SUNROOM





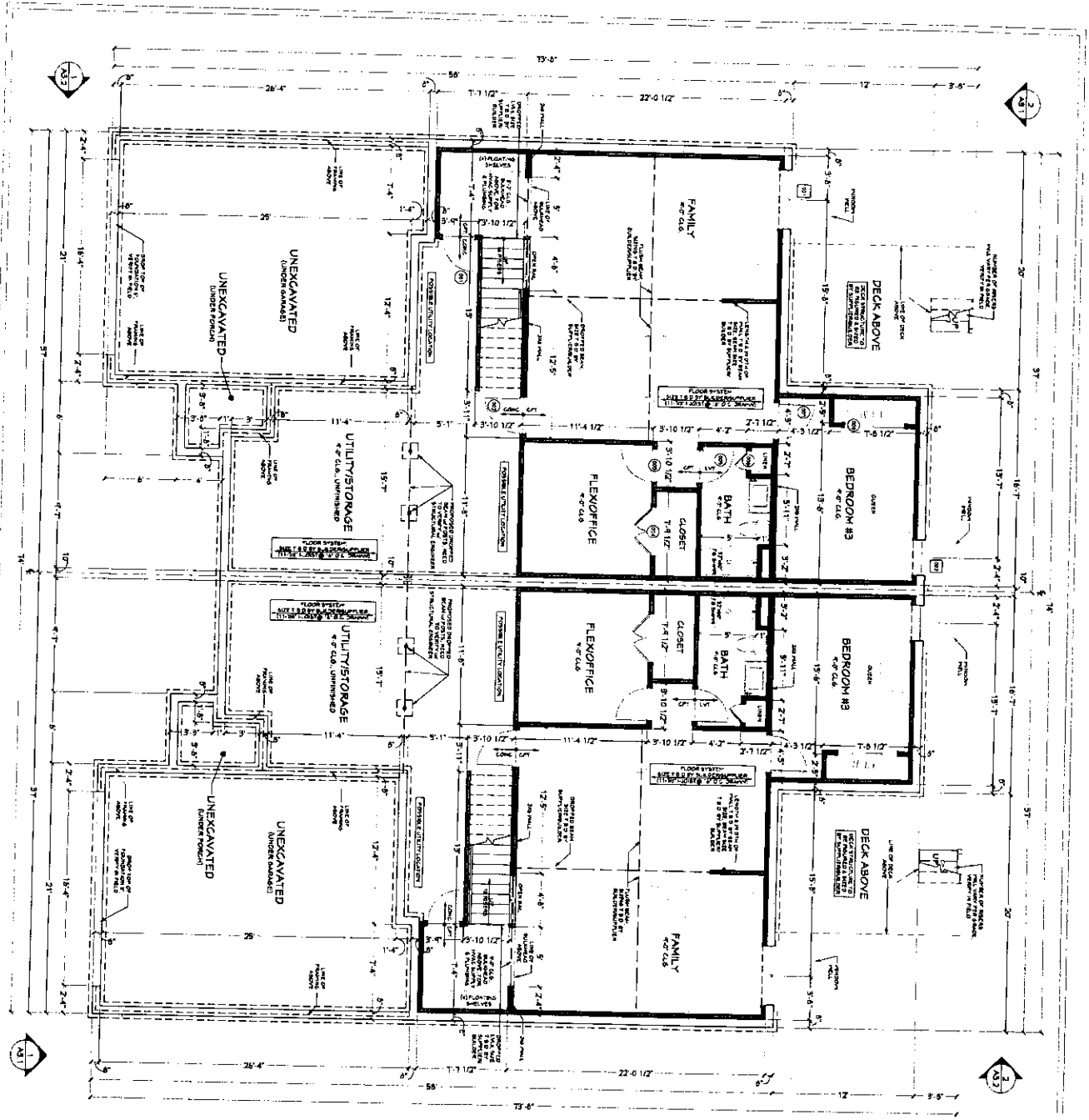

**COMMON/BASEMENT NOTES:**

- 1) Contractor to verify all dimensions prior to start of construction and verify every condition with Designer and/or Owner.
- 2) Contractor to verify local codes that are applicable to the project.
- 3) These plans were prepared by a professional engineer.
- 4) All rooms shall be 2' x 4 studs at 16" O.C. All wood framing to be Douglas Fir.
- 5) Interior walls to be 2' x 4 studs at 16" O.C. All wood framing to be Douglas Fir.
- 6) All exterior walls shall be 2' x 4 studs at 16" O.C. All wood framing to be Douglas Fir.
- 7) All HVAC, Plumbing, and Electrical work to be designed and installed by a licensed professional.
- 8) All electrical work shall be installed by a licensed electrician.
- 9) All plumbing work shall be installed by a licensed plumber.
- 10) All mechanical work shall be installed by a licensed mechanical contractor.

**NOTE:**

- CEILING HEIGHT FOR BASEMENT LEVEL: 10'0" S.F.
- FLOOR FINISHES: OVERCAST CONCRETE, 0" OR 6" P.C.

**WINDOW NOTES:**

- SPECIFICATIONS SHALL BE PROVIDED WITHIN 60 DAYS OF THE START OF CONSTRUCTION.
- ALL WINDOWS SHALL BE 20" MIN. CLEARANCE FROM THE FINISH FLOOR HEIGHT.
- ALL WINDOWS SHALL BE 20" MIN. CLEARANCE FROM THE FINISH FLOOR HEIGHT.
- ALL WINDOWS SHALL BE 20" MIN. CLEARANCE FROM THE FINISH FLOOR HEIGHT.

**NUMBER IDENTIFICATION:**

NUMBER IDENTIFICATION	DESCRIPTION	QUANTITY	UNIT
001	CONCRETE	100	YD
002	SPRING DOOR	2	EA
003	SPRING DOOR	2	EA
004	SPRING DOOR	2	EA
005	SPRING DOOR	2	EA
006	SPRING DOOR	2	EA
007	SPRING DOOR	2	EA
008	SPRING DOOR	2	EA
009	SPRING DOOR	2	EA
010	SPRING DOOR	2	EA
011	SPRING DOOR	2	EA
012	SPRING DOOR	2	EA
013	SPRING DOOR	2	EA
014	SPRING DOOR	2	EA
015	SPRING DOOR	2	EA
016	SPRING DOOR	2	EA
017	SPRING DOOR	2	EA
018	SPRING DOOR	2	EA
019	SPRING DOOR	2	EA
020	SPRING DOOR	2	EA

**NUMBER IDENTIFICATION: WINDOW SCHEDULE FOR BASEMENT LEVEL ONLY**

NUMBER IDENTIFICATION	DESCRIPTION	QUANTITY	UNIT
001	WINDOW	10	EA
002	WINDOW	10	EA
003	WINDOW	10	EA
004	WINDOW	10	EA
005	WINDOW	10	EA
006	WINDOW	10	EA
007	WINDOW	10	EA
008	WINDOW	10	EA
009	WINDOW	10	EA
010	WINDOW	10	EA
011	WINDOW	10	EA
012	WINDOW	10	EA
013	WINDOW	10	EA
014	WINDOW	10	EA
015	WINDOW	10	EA
016	WINDOW	10	EA
017	WINDOW	10	EA
018	WINDOW	10	EA
019	WINDOW	10	EA
020	WINDOW	10	EA

**AREA SCHEDULE:**

AREA SCHEDULE	DESCRIPTION	QUANTITY	UNIT
001	FULL BASEMENT	100	YD
002	CONCRETE	100	YD
003	SPRING DOOR	2	EA
004	SPRING DOOR	2	EA
005	SPRING DOOR	2	EA
006	SPRING DOOR	2	EA
007	SPRING DOOR	2	EA
008	SPRING DOOR	2	EA
009	SPRING DOOR	2	EA
010	SPRING DOOR	2	EA
011	SPRING DOOR	2	EA
012	SPRING DOOR	2	EA
013	SPRING DOOR	2	EA
014	SPRING DOOR	2	EA
015	SPRING DOOR	2	EA
016	SPRING DOOR	2	EA
017	SPRING DOOR	2	EA
018	SPRING DOOR	2	EA
019	SPRING DOOR	2	EA
020	SPRING DOOR	2	EA

**TOTAL CONCRETE: 100 YD**

**TOTAL SPRING DOOR: 20 EA**

**TOTAL WINDOW: 100 EA**

**TOTAL UNEXCAVATED SPACE: 1,000 SQ. FT.**

**TOTAL CONCRETE: 100 YD**

**TOTAL SPRING DOOR: 20 EA**

**TOTAL WINDOW: 100 EA**

**TOTAL UNEXCAVATED SPACE: 1,000 SQ. FT.**

**PRICING SET - NOT FOR CONSTRUCTION**

**BASEMENT / FOUNDATION PLAN - FULL BASEMENT**

**'NEW ERA' TOWNHOMES - PLAT 10 ADDRESS T.B.D.**

**SPEC UNITS W/ SUNROOM**

**GBH**

**DATE: 4/20/20**

**SHEET: A0.1**

**DRAWINGS PROVIDED BY: ARCHITECTURAL MODELING INC.**

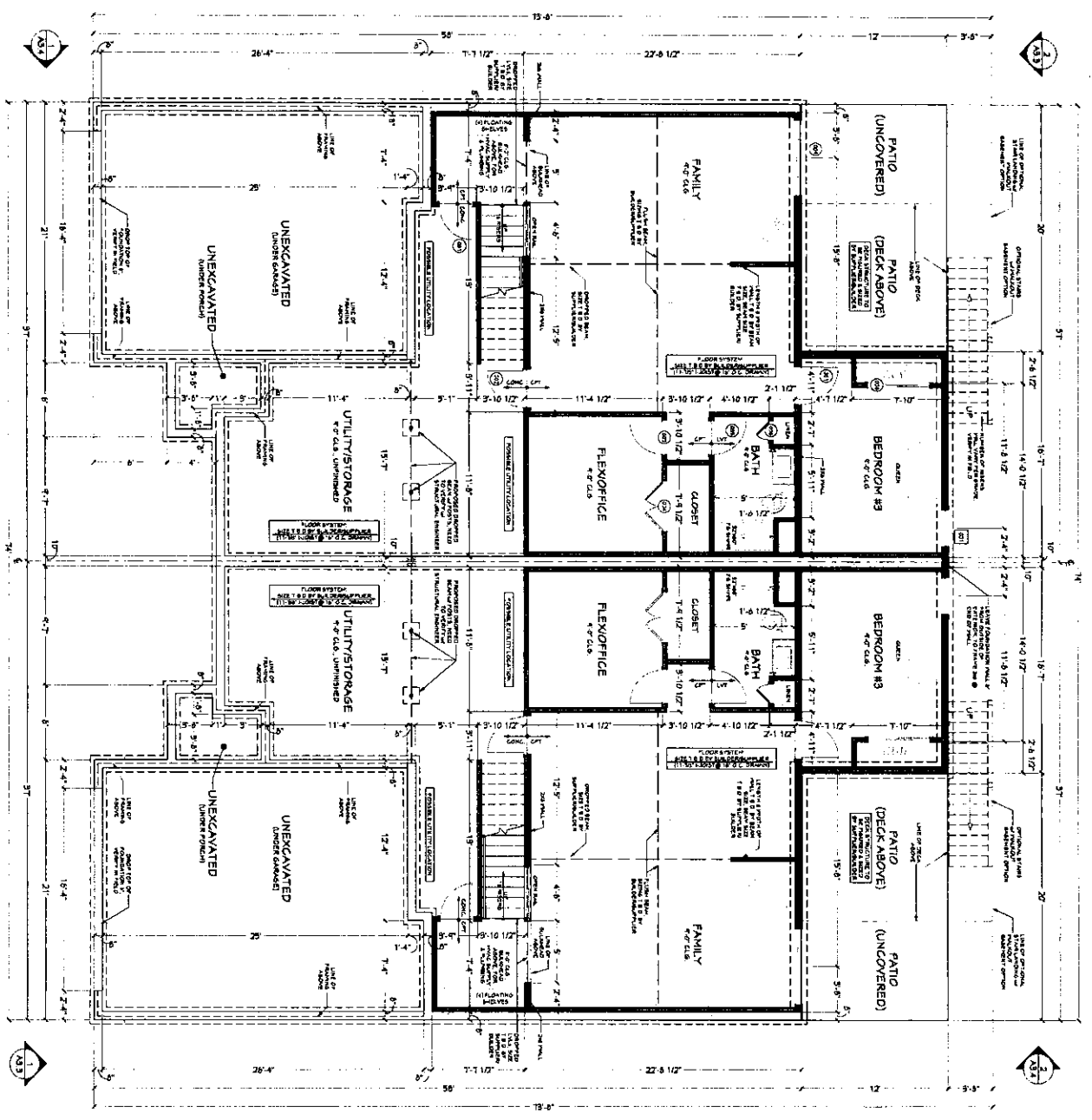

**BASEMENT / FOUNDATION PLAN - WALKOUT**  
 SCALE: 3/8"=1'-0"

AREA SCHEDULE	
WALKOUT BASEMENT SUNROOM	30.77
UNEXCAVATED	431.00
TOTAL UNEXCAVATED	461.77
TOTAL GROSS LIVING SPACE	1,825
TOTAL GROSS FINISH SPACE	2,695
TOTAL FINISHED BASEMENT	1,091
TOTAL FINISHED BASEMENT	1,091
TOTAL OUTDOOR SPACE	1.84

NUMBER	DESCRIPTION	UNIT	AMOUNT	REMARKS
001	DOOR SCHEDULE / BASEMENT (PER UNIT)			
002	DOOR SCHEDULE / BASEMENT (PER UNIT)			
003	DOOR SCHEDULE / BASEMENT (PER UNIT)			
004	DOOR SCHEDULE / BASEMENT (PER UNIT)			
005	DOOR SCHEDULE / BASEMENT (PER UNIT)			
006	DOOR SCHEDULE / BASEMENT (PER UNIT)			
007	DOOR SCHEDULE / BASEMENT (PER UNIT)			
008	DOOR SCHEDULE / BASEMENT (PER UNIT)			
009	DOOR SCHEDULE / BASEMENT (PER UNIT)			
010	DOOR SCHEDULE / BASEMENT (PER UNIT)			
011	DOOR SCHEDULE / BASEMENT (PER UNIT)			
012	DOOR SCHEDULE / BASEMENT (PER UNIT)			
013	DOOR SCHEDULE / BASEMENT (PER UNIT)			
014	DOOR SCHEDULE / BASEMENT (PER UNIT)			
015	DOOR SCHEDULE / BASEMENT (PER UNIT)			
016	DOOR SCHEDULE / BASEMENT (PER UNIT)			
017	DOOR SCHEDULE / BASEMENT (PER UNIT)			
018	DOOR SCHEDULE / BASEMENT (PER UNIT)			
019	DOOR SCHEDULE / BASEMENT (PER UNIT)			
020	DOOR SCHEDULE / BASEMENT (PER UNIT)			
021	DOOR SCHEDULE / BASEMENT (PER UNIT)			
022	DOOR SCHEDULE / BASEMENT (PER UNIT)			
023	DOOR SCHEDULE / BASEMENT (PER UNIT)			
024	DOOR SCHEDULE / BASEMENT (PER UNIT)			
025	DOOR SCHEDULE / BASEMENT (PER UNIT)			
026	DOOR SCHEDULE / BASEMENT (PER UNIT)			
027	DOOR SCHEDULE / BASEMENT (PER UNIT)			
028	DOOR SCHEDULE / BASEMENT (PER UNIT)			
029	DOOR SCHEDULE / BASEMENT (PER UNIT)			
030	DOOR SCHEDULE / BASEMENT (PER UNIT)			
031	DOOR SCHEDULE / BASEMENT (PER UNIT)			
032	DOOR SCHEDULE / BASEMENT (PER UNIT)			
033	DOOR SCHEDULE / BASEMENT (PER UNIT)			
034	DOOR SCHEDULE / BASEMENT (PER UNIT)			
035	DOOR SCHEDULE / BASEMENT (PER UNIT)			
036	DOOR SCHEDULE / BASEMENT (PER UNIT)			
037	DOOR SCHEDULE / BASEMENT (PER UNIT)			
038	DOOR SCHEDULE / BASEMENT (PER UNIT)			
039	DOOR SCHEDULE / BASEMENT (PER UNIT)			
040	DOOR SCHEDULE / BASEMENT (PER UNIT)			
041	DOOR SCHEDULE / BASEMENT (PER UNIT)			
042	DOOR SCHEDULE / BASEMENT (PER UNIT)			
043	DOOR SCHEDULE / BASEMENT (PER UNIT)			
044	DOOR SCHEDULE / BASEMENT (PER UNIT)			
045	DOOR SCHEDULE / BASEMENT (PER UNIT)			
046	DOOR SCHEDULE / BASEMENT (PER UNIT)			
047	DOOR SCHEDULE / BASEMENT (PER UNIT)			
048	DOOR SCHEDULE / BASEMENT (PER UNIT)			
049	DOOR SCHEDULE / BASEMENT (PER UNIT)			
050	DOOR SCHEDULE / BASEMENT (PER UNIT)			
051	DOOR SCHEDULE / BASEMENT (PER UNIT)			
052	DOOR SCHEDULE / BASEMENT (PER UNIT)			
053	DOOR SCHEDULE / BASEMENT (PER UNIT)			
054	DOOR SCHEDULE / BASEMENT (PER UNIT)			
055	DOOR SCHEDULE / BASEMENT (PER UNIT)			
056	DOOR SCHEDULE / BASEMENT (PER UNIT)			
057	DOOR SCHEDULE / BASEMENT (PER UNIT)			
058	DOOR SCHEDULE / BASEMENT (PER UNIT)			
059	DOOR SCHEDULE / BASEMENT (PER UNIT)			
060	DOOR SCHEDULE / BASEMENT (PER UNIT)			
061	DOOR SCHEDULE / BASEMENT (PER UNIT)			
062	DOOR SCHEDULE / BASEMENT (PER UNIT)			
063	DOOR SCHEDULE / BASEMENT (PER UNIT)			
064	DOOR SCHEDULE / BASEMENT (PER UNIT)			
065	DOOR SCHEDULE / BASEMENT (PER UNIT)			
066	DOOR SCHEDULE / BASEMENT (PER UNIT)			
067	DOOR SCHEDULE / BASEMENT (PER UNIT)			
068	DOOR SCHEDULE / BASEMENT (PER UNIT)			
069	DOOR SCHEDULE / BASEMENT (PER UNIT)			
070	DOOR SCHEDULE / BASEMENT (PER UNIT)			
071	DOOR SCHEDULE / BASEMENT (PER UNIT)			
072	DOOR SCHEDULE / BASEMENT (PER UNIT)			
073	DOOR SCHEDULE / BASEMENT (PER UNIT)			
074	DOOR SCHEDULE / BASEMENT (PER UNIT)			
075	DOOR SCHEDULE / BASEMENT (PER UNIT)			

**FOUNDATION NOTES:**

- 1) Contractor to verify all dimensions prior to start of construction and resolve any concerns with Designer and/or Owner.
- 2) Owner to verify final notes that are applicable to this project and correct all in conflicts with these notes.
- 3) These plans have not been certified by a structural engineer.
- 4) All exterior walls to be 2" x 8 studs @ 16" o.c. All wood framing to be Douglas Fir.
- 5) Interior walls to be 2" x 4 studs @ 16" o.c. All wood framing to be Douglas Fir.
- 6) All exterior walls are shown with 2x4 studs. Substrate 2x6 studs if needed or needed.
- 7) All RMC, Plumbing, and Electrical work to be designed by others.
- 8) All wood in contact with earth or concrete to be treated.
- 9) Sunrooms with floor windows are required to have a structural engineer design and certify.
- 10) Provide structural member certified smolea design as required by governing local codes. -Reinforced smolea design with necessary steel to be provided on every floor in sunroom areas.

**WINDOW NOTES:**

EVERY WINDOW SHALL BE PROVIDED WITH AN ENERGY EFFICIENT WINDOW. ALL WINDOWS SHALL BE 1/2" MINIMUM CLEARANCE FROM WALL AND SHALL HAVE A MINIMUM OVERLAP OF 1/2" FROM THE WALL. ALL WINDOWS SHALL BE 1/2" MINIMUM CLEARANCE FROM WALL AND SHALL HAVE A MINIMUM OVERLAP OF 1/2" FROM THE WALL.

**NOTE:**

- SEE AND VERIFY FOR ALL DIMENSIONS PRIOR TO START OF CONSTRUCTION.
- ALL DIMENSIONS SHALL BE IN UNITS OF FEET AND INCHES UNLESS OTHERWISE NOTED.

PRICING SET - NOT FOR CONSTRUCTION

DATE: 4/20/20 SHEET: A0.2	DRAWINGS PROVIDED BY: <b>RESIDENTIAL MODELING DESIGNS</b>	<b>BASEMENT / FOUNDATION PLAN - WALKOUT</b>	<b>'NEW ERA' TOWNHOMES - PLAT 10</b> ADDRESS T.B.D.	<b>SPEC UNITS W/ SUNROOM</b>	
------------------------------	--	---	--	------------------------------	--

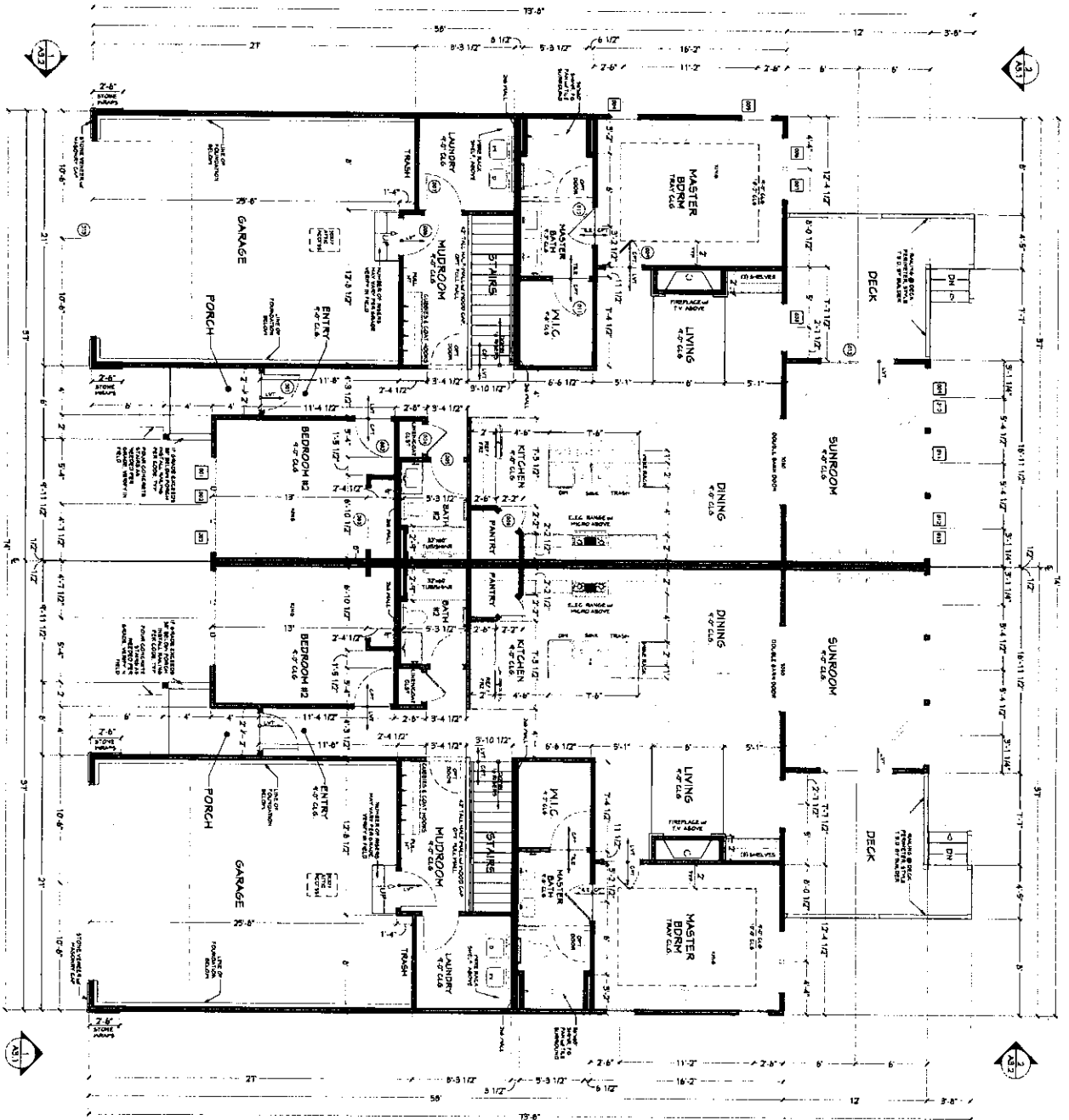

**FLOOR PLAN NOTES:**

- 1) Contractor to verify all dimensions prior to start of construction and resolve any concerns with designer or owner.
- 2) Contractor to verify local codes that are applicable to this project and include all in contract with these codes.
- 3) All materials to be installed by a approved engineer.
- 4) Exterior and interior walls to be 2 x 4 studs at 16" o.c. unless noted otherwise. All wood framing to be Douglas Fir.
- 5) Doors are to be 30" high and 36" wide. Schedule 80 rods if desired or needed.
- 6) Double doors are to be 30" high and 72" wide. Schedule 80 rods if desired or needed.
- 7) Truss manufacturer to site members, trusses, and set spacing of all roof and floor trusses for required design loads (minimum spacing 24" o.c.). Total truss and floor truss spacing to be 24" o.c. unless noted otherwise.
- 8) Slab finish to work with an 1 1/2" thick floor system. Actual finish as needed after floor system is determined.
- 9) All roof, framing, and structural work to be designed by others.
- 10) All roof framing to be designed by others.
- 11) All attic and other enclosed spaces to be ventilated with screen soffit vents.
- 12) Install an exhaust fan with 22" x 22" minimum with 30" clearance above the opening in all attic and other enclosed spaces to be ventilated with screen soffit vents.
- 13) All doors and steel framing shall be installed no more than 4" apart.
- 14) Bathrooms without windows are required to have a ventilation fan that provides 100 CFM of airflow. Bathrooms with windows are required to have a fan that provides 100 CFM of airflow. Fan to be installed in sleeping room, and hall or area giving access to sleeping room.

**NOTE:**

- CEILING HEIGHT FROM BASEMENT LEVEL TO BE 8'-6"
- FLOOR FINISHES TO BE 1 1/2" MINIMUM
- FLOOR FINISHES FOR MAIN FLOOR TO BE 3/4"

**WINDOW NOTES:**

FOR ALL WINDOWS, UNLESS OTHERWISE NOTED, ALL WINDOWS SHALL BE 1/2" MINIMUM CLEARANCE FROM THE FINISH FLOOR TO THE FINISH CEILING AND 1/2" MINIMUM CLEARANCE FROM THE FINISH FLOOR TO THE FINISH WALL. UNLESS OTHERWISE NOTED, ALL WINDOWS SHALL BE 1/2" MINIMUM CLEARANCE FROM THE FINISH FLOOR TO THE FINISH WALL.

NUMBER	DESCRIPTION	QUANTITY	UNIT	REMARKS
001	CEILING	1	SQ. FT.	
002	FLOOR	1	SQ. FT.	
003	WALL	1	SQ. FT.	
004	DOOR	1	EA.	
005	WINDOW	1	EA.	
006	TRUSS	1	EA.	
007	SLAB	1	SQ. FT.	
008	ROOF	1	SQ. FT.	
009	FRAMING	1	SQ. FT.	
010	INSULATION	1	SQ. FT.	
011	MECHANICAL	1	EA.	
012	ELECTRICAL	1	EA.	
013	PLUMBING	1	EA.	
014	PAINT	1	SQ. FT.	
015	FINISH	1	SQ. FT.	

NUMBER	DESCRIPTION	QUANTITY	UNIT	REMARKS
001	CEILING	1	SQ. FT.	
002	FLOOR	1	SQ. FT.	
003	WALL	1	SQ. FT.	
004	DOOR	1	EA.	
005	WINDOW	1	EA.	
006	TRUSS	1	EA.	
007	SLAB	1	SQ. FT.	
008	ROOF	1	SQ. FT.	
009	FRAMING	1	SQ. FT.	
010	INSULATION	1	SQ. FT.	
011	MECHANICAL	1	EA.	
012	ELECTRICAL	1	EA.	
013	PLUMBING	1	EA.	
014	PAINT	1	SQ. FT.	
015	FINISH	1	SQ. FT.	

AREA SCHEDULE	
WALL	507.7
FLOOR	517.0
CEILING	517.0
DOOR	1.0
WINDOW	1.0
TRUSS	1.0
SLAB	1.0
ROOF	1.0
FRAMING	1.0
INSULATION	1.0
MECHANICAL	1.0
ELECTRICAL	1.0
PLUMBING	1.0
PAINT	1.0
FINISH	1.0
TOTAL	1,523.7

**MAIN FLOOR PLAN -  
w/ FULL BASEMENT**  
SCALE: 3/4"=1'-0"

**PRICING SET - NOT FOR CONSTRUCTION**

DATE: 4/20/20  
SHEET: A1.1

**MAIN FLOOR PLAN -  
w/ FULL BASEMENT**

**'NEW ERA'  
TOWNHOMES -  
PLAT 10  
ADDRESS T.B.D.**

**SPEC UNITS W/  
SUNROOM**





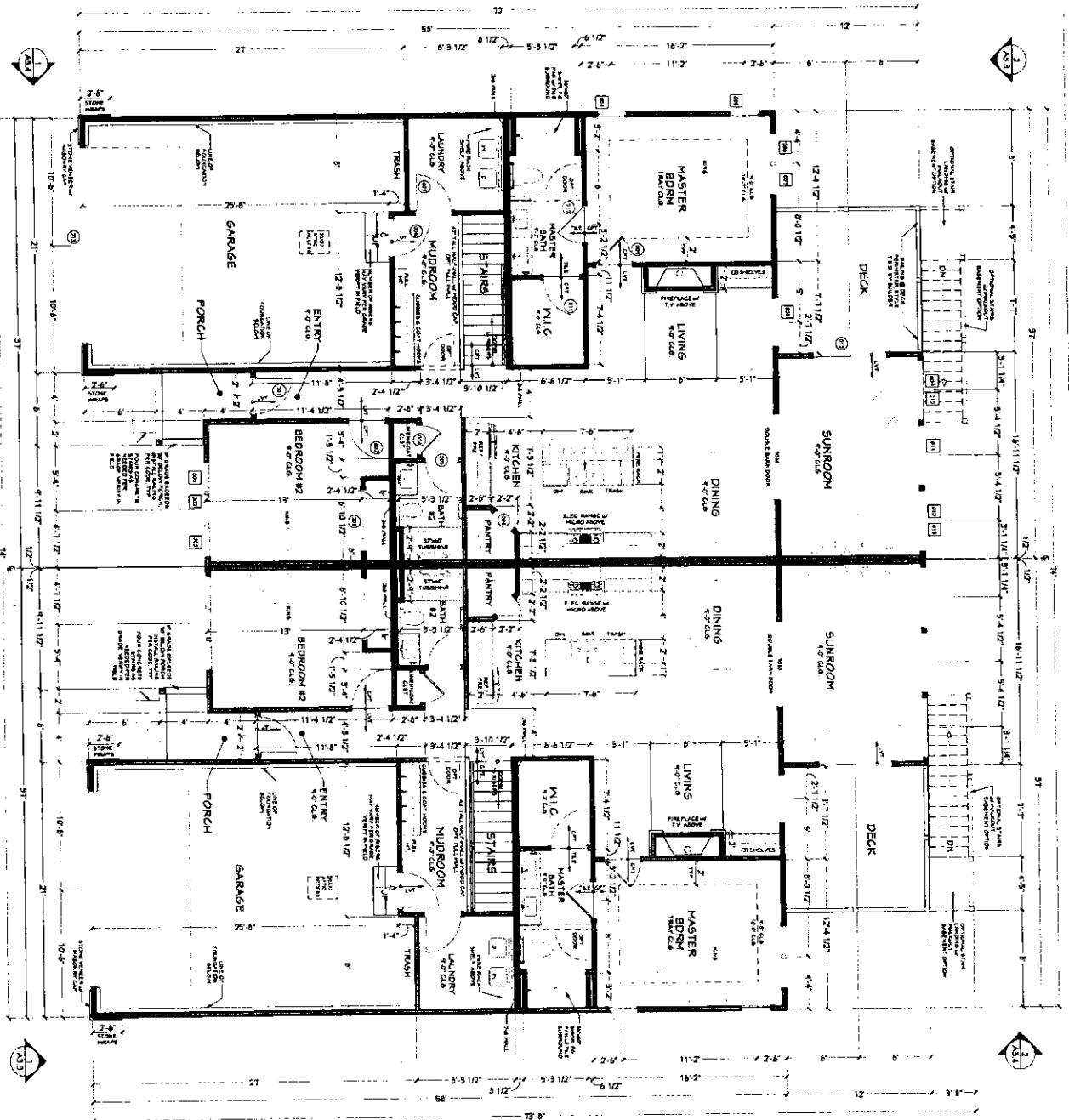

**EXERCISE PLAN NOTES:**

- 1) Contractor to verify all dimensions prior to start of construction and resolve any concerns with Designer and/or Owner.
- 2) All dimensions are in feet and inches that are applicable to this project and construct all in accordance with these notes.
- 3) These points have not been certified by a structural engineer.
- 4) Elevation and foundation for 10' x 4' x 4' walls at 10' o.c. vertical rod spacing. All wood framing shall be 2x4's.
- 5) All framing shall be drawn with 2x4 studs. Substituting 2x6 studs if deemed or needed by the Designer.
- 6) Double floor joists under garage shall be 2x12's.
- 7) Double floor joists under roof shall be 2x12's.
- 8) Double floor joists under roof shall be 2x12's.
- 9) Start figure to be worked on 11/72" just floor system, adjust floor as needed after 9) is done.
- 10) All wood in contact with earth or concrete to be treated with preservative.
- 11) All wood in contact with earth or concrete to be treated with preservative.
- 12) Install an access scissor of 2x2" x 30" minimum with 3/8" hardware above the opening in the garage.
- 13) Provide and install locally certified single anchors as required by governing local codes. Horizontal anchors shall be installed with 3/8" hardware on each floor in each sleeping room and full or area being accessed to sleeping room.

**NOTE:**

- \* Railing height for balustrade level to be 3'6"
- \* Railing height for main floor level to be 3'0"
- \* Floor structure for main floor 1.5.0

**WINDOW NOTES:**

EVERY WINDOW SHALL BE PROVIDED WITH AN ENERGY STAR RATED WINDOW. ALL WINDOW UNITS SHALL HAVE A MINIMUM U-FACTOR OF 0.31 AND AN ENERGY EFFICIENCY RATING OF 1 STAR OR BETTER. WINDOW UNITS SHALL BE 3/4" WIDE ON 3/4" HIGH.

**DOOR SCHEDULE (MAIN FLOOR COMPONENTS)**

NUMBER	DOOR TYPE	FINISH	HEIGHT	COMMENTS
001	ENTRY DOOR	6-0"	6-8"	
002	ENTRY DOOR	6-0"	6-8"	
003	ENTRY DOOR	6-0"	6-8"	
004	ENTRY DOOR	6-0"	6-8"	
005	ENTRY DOOR	6-0"	6-8"	
006	ENTRY DOOR	6-0"	6-8"	
007	ENTRY DOOR	6-0"	6-8"	
008	ENTRY DOOR	6-0"	6-8"	
009	ENTRY DOOR	6-0"	6-8"	
010	ENTRY DOOR	6-0"	6-8"	
011	ENTRY DOOR	6-0"	6-8"	
012	ENTRY DOOR	6-0"	6-8"	
013	ENTRY DOOR	6-0"	6-8"	

**FINISH SCHEDULE (MAIN FLOOR COMPONENTS)**

NUMBER	FINISH TYPE	FINISH	HEIGHT	COMMENTS
001	WALL	9-0"	9-0"	
002	WALL	9-0"	9-0"	
003	WALL	9-0"	9-0"	
004	WALL	9-0"	9-0"	
005	WALL	9-0"	9-0"	
006	WALL	9-0"	9-0"	
007	WALL	9-0"	9-0"	
008	WALL	9-0"	9-0"	
009	WALL	9-0"	9-0"	
010	WALL	9-0"	9-0"	
011	WALL	9-0"	9-0"	
012	WALL	9-0"	9-0"	
013	WALL	9-0"	9-0"	

**AREA SCHEDULE - WALKOUT BASEMENT & SUNROOM**

DESCRIPTION	AREA (SQ. FT.)	COMMENTS
WALKOUT BASEMENT	491	CONCRETE
SUNROOM	396	CONCRETE
TOTAL WALKOUT BASEMENT & SUNROOM	887	
TOTAL FINISHED SPACE	1,097	
TOTAL UNFINISHED SPACE	1,097	
TOTAL FINISHED SPACE	1,097	
TOTAL UNFINISHED SPACE	194	

**MAIN FLOOR PLAN - W/ WALKOUT BASEMENT**  
SCALE: 3/8" = 1'-0"

PRICING SET - NOT FOR CONSTRUCTION

SHEET: A1.2

DATE: 4/20/20

DRAWINGS PROVIDED BY:  
**RESIDENTIAL REMODELING DESIGN**

MAIN FLOOR PLAN - W/ WALKOUT BASEMENT

NEW ERA TOWNHOMES - PLAT 10 ADDRESS T.B.D.

SPEC UNITS W/ SUNROOM



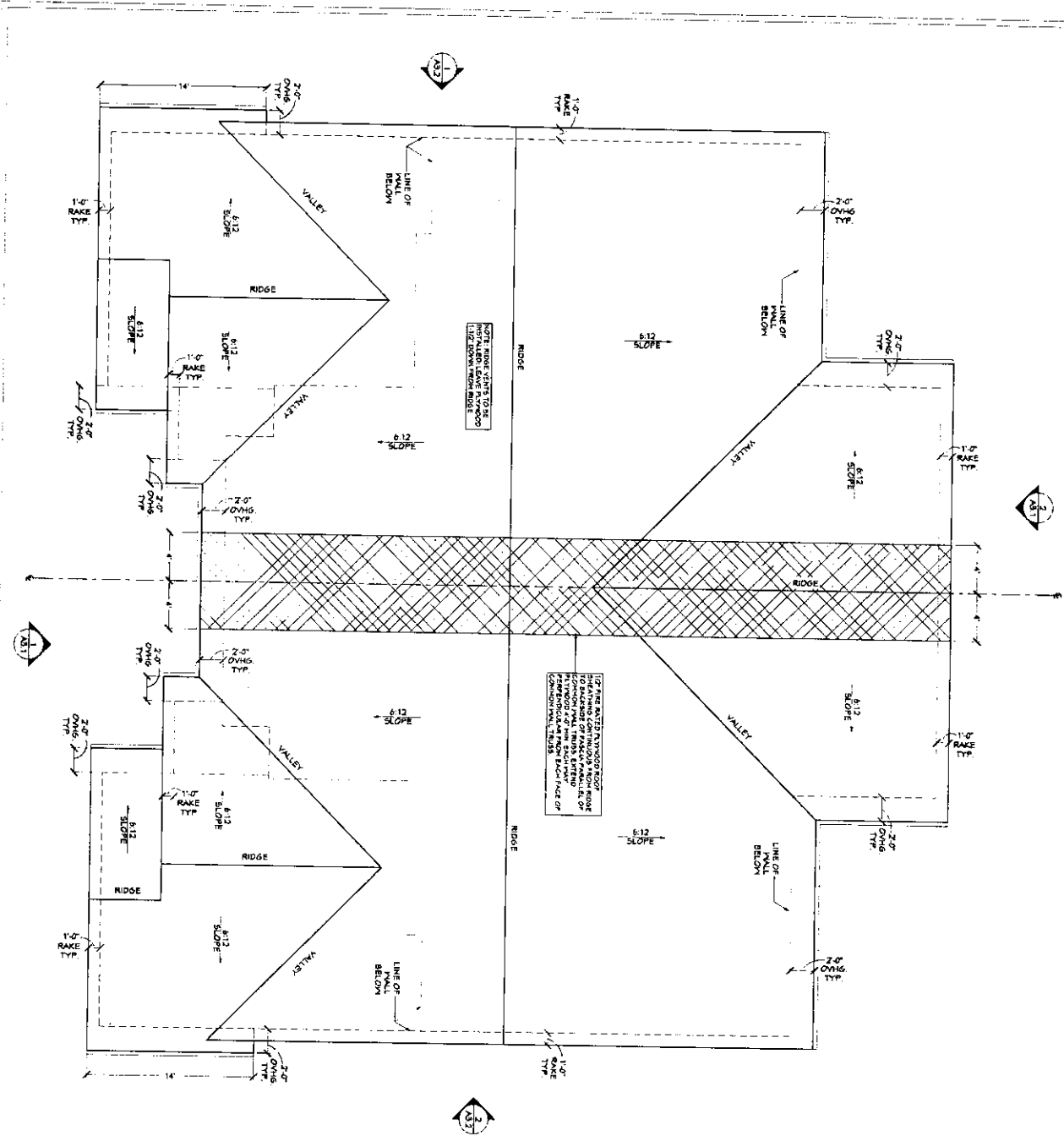

NOTE: RIDGE HEIGHT TO BE DETERMINED BY LOCAL CODES. SEE LOCAL CODES FOR MINIMUM RISE.

IF THE WATER DRAINAGE ROOF IS TO BE USED, THE CONTRACTOR SHALL PROVIDE A DRAINAGE SYSTEM FROM EACH RIDGE AND VALLEY. THE DRAINAGE SYSTEM SHALL BE INSTALLED FROM EACH FACE OF THE ROOF.

- ROOF PLAN:
- 1) Contractor to verify all dimensions prior to start of construction and provide any corrections with Designer and/or Owner.
  - 2) Contractor to verify local codes that are applicable to this project.
  - 3) These plans have not been certified by a structural engineer.
  - 4) These plans are to be used for information only and are not to be used for construction.
  - 5) Minimum truss-to-truss framing heights are 8' with lowest eave. Eave height and height are a minimum 12' from eave to ridge. Truss heights are to be set to match with the same framing dimension.
  - 6) All roof overhangs are 24" unless noted otherwise.
  - 7) All gables and other vertical surfaces to be finished with screen with vents.
  - 8) Truss spacing shall be 22' x 20' minimum with 30' maximum spacing.
  - 9) Contractor shall be responsible for ensuring all framing, underlayment and roof penetrations are consistent with industry standards & methods.

1 ROOF PLAN  
SCALE: 2/8"=1'-0"

AREA SCHEDULE		TOTAL DIMENSION OF SUNROOM	
Roof Area	50	Overall Length	33.17
Truss Area	43	Overall Width	1.85
Underlayment	50	Overall Area	35.02
Roofing	1,040	Overall Volume	41
Other	148	Overall Weight	1,037
TOTAL ROOFING AREA		TOTAL SUNROOM SPACE	
2,071		2,683	
TOTAL SUNROOM SPACE		TOTAL SUNROOM SPACE	
1,037		200	

PRICING SET - NOT FOR CONSTRUCTION

SHEET: A2.1

DATE: 4/20/20  
DRAWINGS PROVIDED BY: RESIDENTIAL MODELING DIMENSIONS

ROOF PLAN

'NEW ERA' TOWNHOMES - PLAT 10 ADDRESS T.B.D.

SPEC UNITS W/ SUNROOM



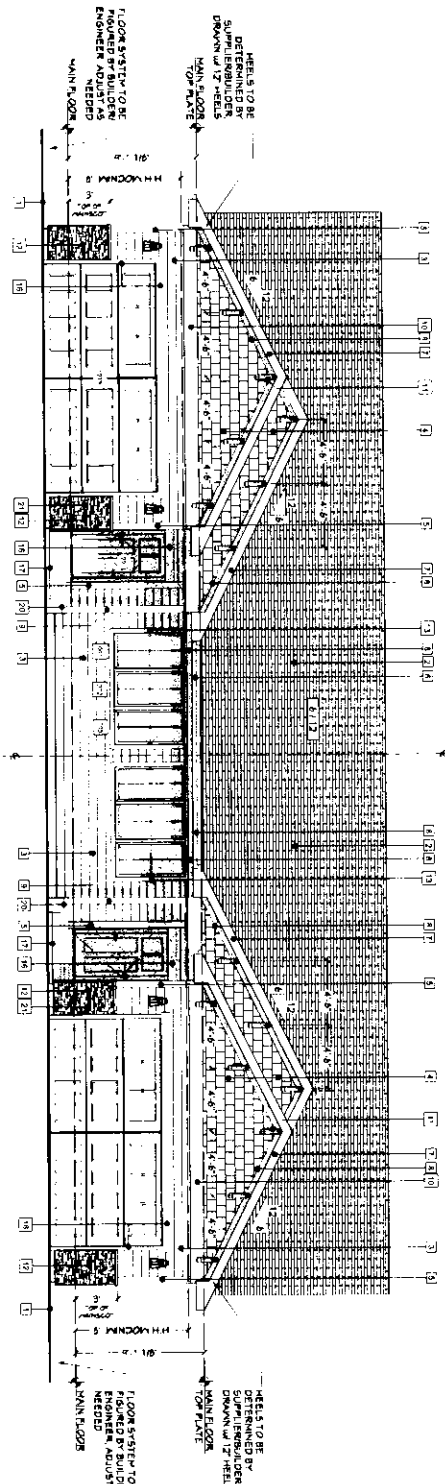

1  
FRONT ELEVATION  
SCALE: 24x36 (1/4\"/>

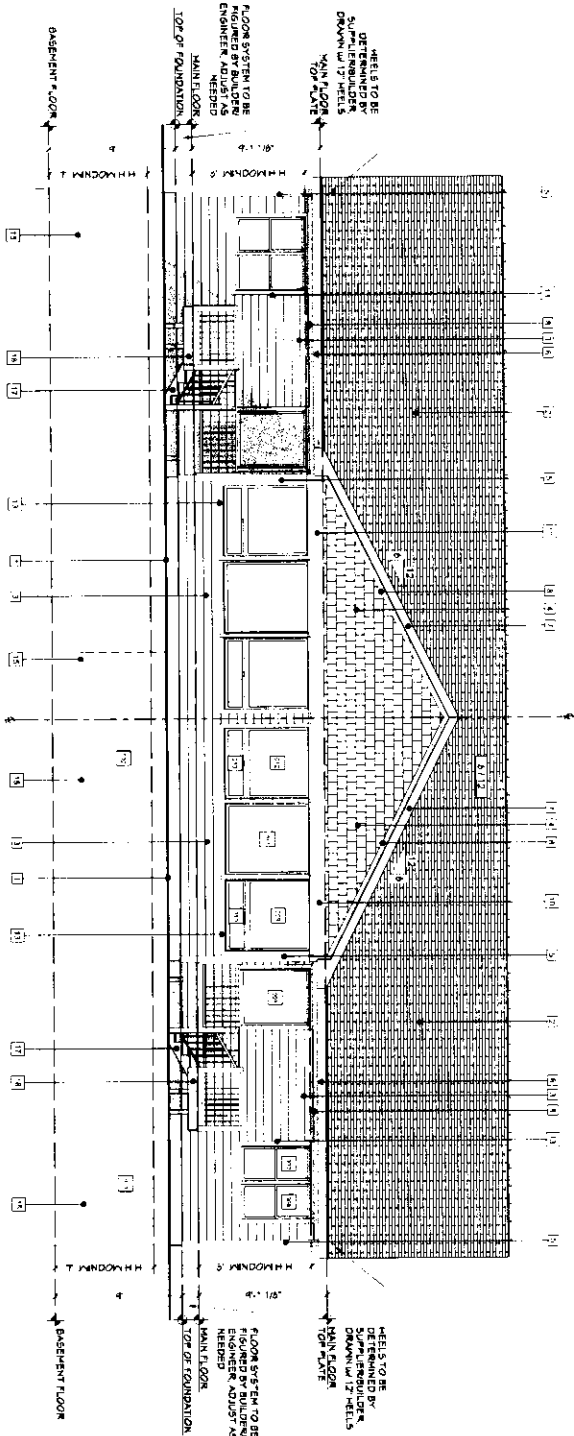

2  
REAR ELEVATION -  
FULL BASEMENT  
SCALE: 24x36 (1/4\"/>

Exterior Note Schedule	
1	LINE OF GRADE, SLOPE AWAY FROM HOUSE
2	ASPHALT/COMPOSITE SHINGLES
3	LAP SIDING, PAINTED FIBER CEMENT (LP OR HARDIE)
4	SHAKE SIDING, PAINTED FIBER CEMENT (LP OR HARDIE)
5	1x6 CORNER BOARD TYP
6	1x8 FASCIA
7	1x8 RAKE
8	1x6 FRIEZE BOARD
9	6x6 WOOD POST
10	1x12 BAND BOARD
11	GABLE BRACKET, 1'8\"/>
12	MANUFACTURED STONE VENEER MANSCOTT W/ PRE-CAST CONCRETE OR MANN STONE CAP
13	WINDOW TRIM 1x4 JAMB & SILL
14	1x4 HEAD TRIM TO FRIEZEBAND WINDOW TRIM 1x4 JAMB, SILL & HEAD TRIM
15	WINDOW WELL
16	DOOR TRIM 1x4 JAMB w/ 1x8 HEAD TRIM, DOOR PER BUILDER
17	STAIRS, BUILD TO GRADE, V.I.F
18	WOOD DECK w/ RAILING STYLE T.B.D BY BUILDER
19	PATIO
20	CONCRETE STOOP
21	LIGHT FIXTURE, EXTERIOR

\* ALL ELEVATIONS & SECTIONS HAVE BEEN DRAWN WITH AN 11\"/>

PRICING SET - NOT FOR CONSTRUCTION

SHEET: A3.1

DATE: 4/20/20

DRAWINGS PROVIDED BY:  
RESIDENTIAL + REMODELING DESIGNS

EXTERIOR ELEVATIONS - FRONT & REAR - FULL BASEMENT

'NEW ERA' TOWNHOMES - PLAT 10 ADDRESS T.B.D.

SPEC UNITS W/ SUNROOM



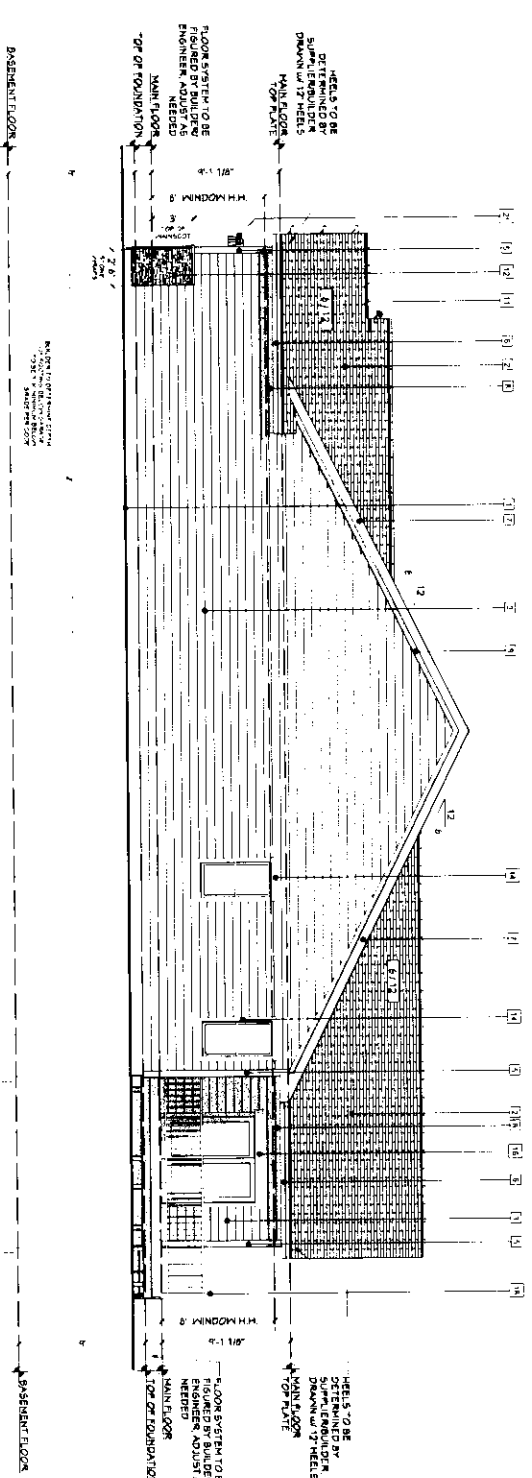

1 LEFT ELEVATION - FULL BASEMENT  
SCALE: 24x36 (1/4"=1'-0")  
12x18 (1/8"=1'-0")

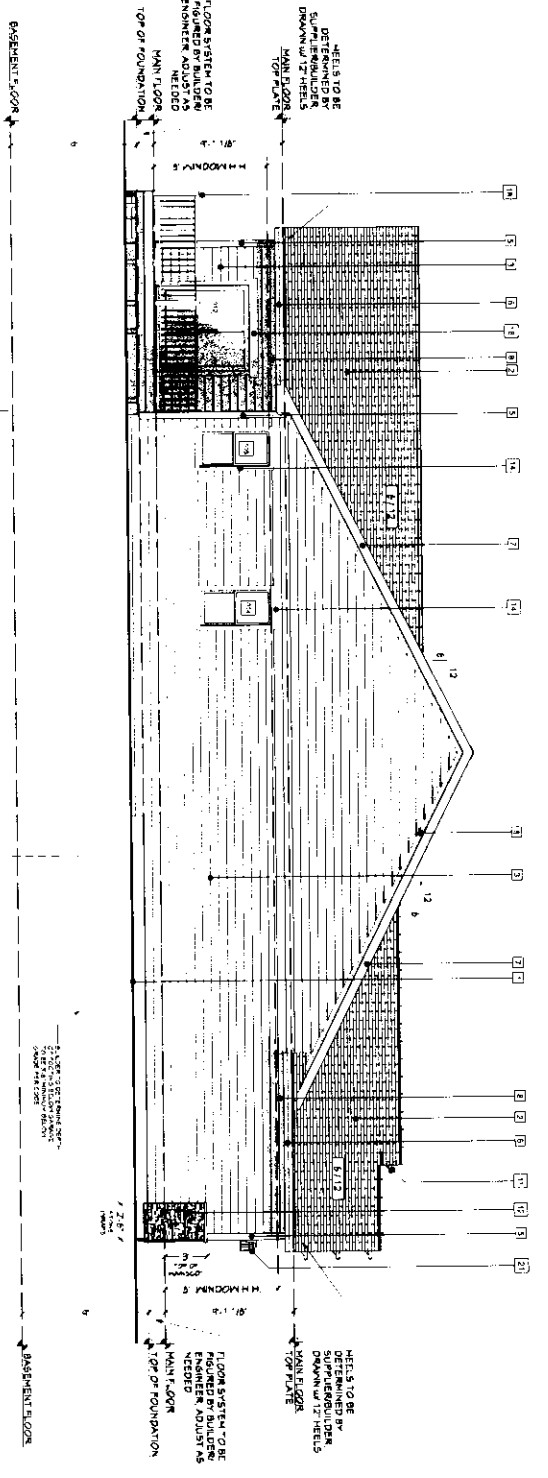

2 RIGHT ELEVATION - FULL BASEMENT  
SCALE: 24x36 (1/4"=1'-0")  
12x18 (1/8"=1'-0")

1	Elevation Note Schedule
1	LINE OF GRADE SLOPE AWAY FROM HOUSE
2	ASPHALT/COMPOSITE SHINGLES
3	LAP SIDING, PAINTED FIBER CEMENT (LP OR HANDED)
4	SHAKE SIDING, PAINTED FIBER CEMENT (LP OR HANDED)
5	1x8 CORNER BOARD, TYP.
6	1x8 FASCIA
7	1x8 RAKE
8	1x8 FREEZE BOARD
9	6x8 WOOD POST
10	1x12 BAND BOARD
11	GABLE BRACKET, 18"x18"x4"
12	MANUFACTURED STONE VENEER WANSBOTT W/ PRE-CAST CONCRETE OR MANN STONE CAP
13	WINDOW TRIM, 1x4 JAMB & SILL, W/ 1x1 HEAD TRIM TO FREEZEBOARD
14	WINDOW TRIM, 1x4 JAMB, SILL & HEAD TRIM
15	WINDOW WELL
16	DOOR TRIM, 1x4 JAMB w/ 1x8 HEAD TRIM, DOOR PER BUILDER
17	STAIRS, BUILT TO GRADE, V.I.F
18	WOOD DECK w/ RAILING, STYLE TBD BY BUILDER
19	PATIO
20	CONCRETE STOOP
21	LIGHT FIXTURE, EXTERIOR

"ALL ELEVATIONAL SECTIONS HAVE BEEN DRAWN WITH AN 11/16" L-0/0" FLOOR SYSTEM @ MAIN FLOOR. THESE DRAWINGS HAVE NOT BEEN REVIEWED BY A STRUCTURAL ENGINEER. FLOOR SYSTEM IS SUBJECT TO CHANGE UPON REVIEW OF STRUCTURAL ENGINEER AND/OR BUILDER."

PRICING SET - NOT FOR CONSTRUCTION

DATE: 4/20/20  
SHEET: A3.2

DRAWINGS PROVIDED BY:  
RESIDENTIAL REMODELING DESIGN

EXTERIOR ELEVATIONS - LEFT & RIGHT - FULL BASEMENT

'NEW ERA' TOWNHOMES - PLAT 10 ADDRESS T.B.D.

SPEC UNITS W/ SUNROOM



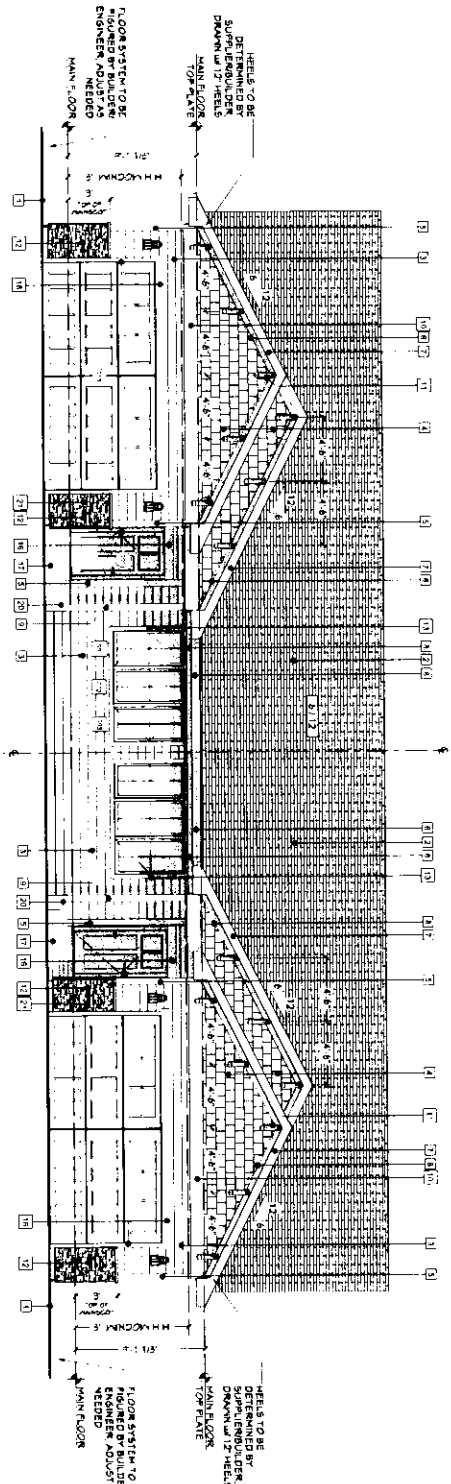

1 FRONT ELEVATION  
SCALE: 24x36 (1/4"=1'-0")  
12x18 (1/8"=1'-0")

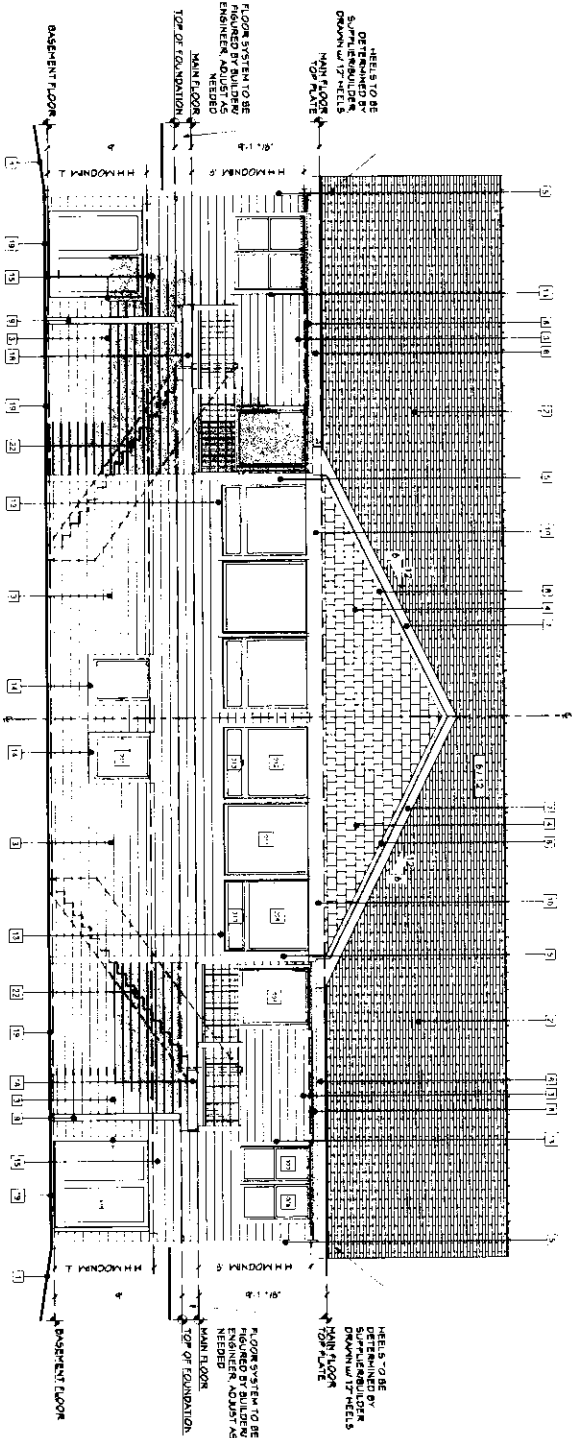

2 REAR ELEVATION -  
WALKOUT BASEMENT  
SCALE: 24x36 (1/4"=1'-0")  
12x18 (1/8"=1'-0")

\*ALL ELEVATIONS & SECTIONS HAVE BEEN DRAWN PER PLAN 11 BY LOBBY TYPING SYSTEM. MAIN FLOOR FINISHES, EXCEPT FOR THE WALKOUT BASEMENT SYSTEM IS SUBJECT TO CHANGE UPON REVIEW OF STRUCTURAL ENGINEER AND/OR BUILDER.

Item	Material / Note
1	LINE OF GRADE ST. OPE AWAY FROM HOUSE
2	ASPHALT/COMPOSITE SHINGLES
3	1/2" LAP SIDING PAINTED FIBER CEMENT (UP OR HANDED) SHAKE SIDING PAINTED FIBER CEMENT (LP OR HANDED)
4	1/8" CORNER BOARD TYP
5	1/4" FASCIA
6	1/4" RAKE
7	1/8" FRIEZE BOARD
8	6x6 WOOD POST
9	1x12 SAND BOARD
10	GABLE BRACKET, 18"x18"x4"
11	HANUFACTURED STONE VENEER MANSICOTT W/ PRE-CAST CONCRETE OR MANE STONE CAP
12	WINDOW TRIM, 1x4 JAMB & SILL W/ 1x1 HEAD TRIM TO FRIEZE/BAND BOARD
13	WINDOW TRIM, 1x4 JAMB, SILL & HEAD
14	HEAD TRIM, 1x4 JAMB W/ 1x8 DOOR TRIM, DOOR PER BUILDER
15	HEAD TRIM, 1x4 JAMB W/ 1x8 DOOR TRIM, DOOR PER BUILDER
16	HEAD TRIM, DOOR PER BUILDER
17	STAIRS, BUILD TO GRADE V.I.F.
18	WOOD/DECK W/ RAILING, STYLE T.B.D. BY BUILDER
19	PATIO
20	CONCRETE STOOP
21	LIGHT FIXTURE, EXTERIOR
22	OPTIONAL STAIRS W/ WALKOUT (OPTION BUILD TO GRADE, V.I.F)

0 PRICING SET - NOT FOR CONSTRUCTION

DATE: 4/20/20  
SHEET: A3.3

DRAWINGS PROVIDED BY:  
RESIDENTIAL + REMODELING DESIGNS

EXTERIOR ELEVATIONS - FRONT & REAR - WALKOUT BASEMENT

'NEW ERA' TOWNHOMES - PLAT 10 ADDRESS T.B.D.

SPEC UNITS W/ SUNROOM



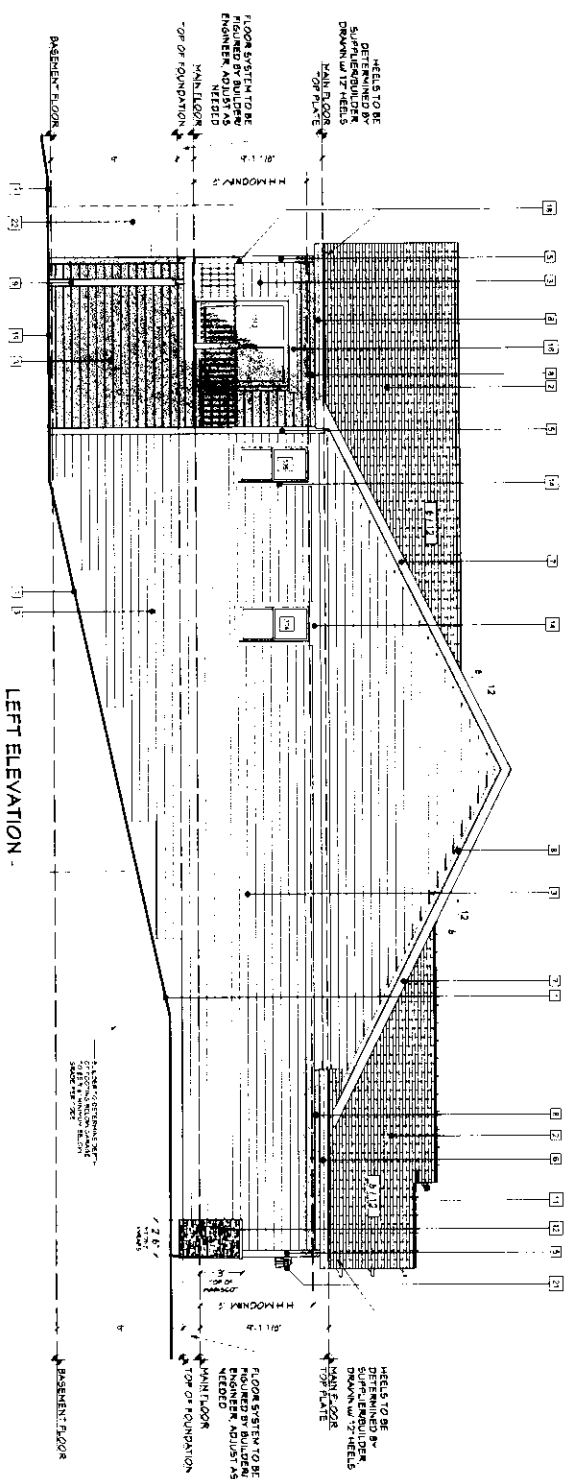

1 LEFT ELEVATION -  
WALKOUT BASEMENT  
SCALE: 24x36 (1/4"=1'-0")  
12x18 (1/8"=1'-0")

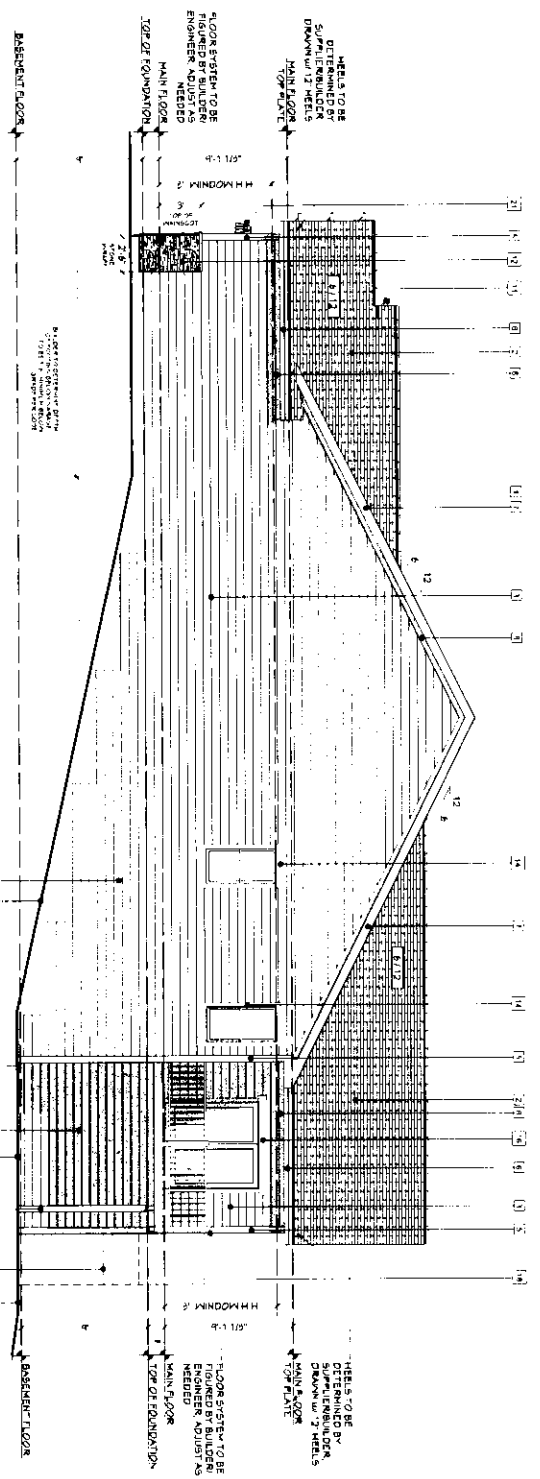

2 RIGHT ELEVATION -  
WALKOUT BASEMENT  
SCALE: 24x36 (1/4"=1'-0")  
12x18 (1/8"=1'-0")

Elevation Note Schedule	
1	LINE OF GRADE, SLOPE AWAY FROM HOUSE
2	ASPHALT/COMPOSITE SHINGLES
3	LAP SIDING, PAINTED FIBER CEMENT (LP OR HARDIE)
4	SHAKE SIDING, PAINTED FIBER CEMENT (LP OR HARDIE)
5	1x6 CORNER BOARD, TYP.
6	1x6 FASCIA
7	1x6 RAKE
8	1x6 FRIEZE BOARD
9	6x8 WOOD POST
10	1x12 BAND BOARD
11	GABLE BRACKET, 18"x18"x4"
12	MANUFACTURED STONE VENEER MANSOOTT w/ PRE-CAST CONCRETE OR MANE STONE CAP
13	WOOD TRIM, 1x4 JAMB & SILL, 1x4 HEAD TRIM TO FRIEZE/BAND WINDOW TRIM, 1x4 JAMB, SILL, & HEAD TRIM
14	HEAD TRIM, 1x4 JAMB w/ 1x8 DOOR TRIM, DOOR PER BUILDER
15	HEAD TRIM, 1x4 JAMB w/ 1x8 DOOR TRIM, DOOR PER BUILDER
16	HEAD TRIM, DOOR PER BUILDER
17	STAIRS, BULD TO GRADE, V.I.F
18	WOOD DECK w/ RAILING, STYLE T.B.D. BY BUILDER
19	PATIO
20	CONCRETE STOOP
21	LIGHT FIXTURE, EXTERIOR
22	OPTIONAL STAIRS w/ WALKOUT OPTION, BULD TO GRADE, V.I.F

\* ALL ELEVATIONS & SECTIONS HAVE BEEN DRAWN WITH AN 11'10" LOSE FLOOR SYSTEM @ MAIN FLOOR. THESE DRAWINGS HAVE NOT BEEN REVIEWED BY A STRUCTURAL ENGINEER. FLOOR SYSTEM IS SUBJECT TO CHANGE UPON REVIEW OF STRUCTURAL ENGINEER AND/OR BUILDER.

PRICING SET - NOT FOR CONSTRUCTION

DATE: 4/20/20  
SHEET: A3.4

DRAWINGS PROVIDED BY:  
RESIDENTIAL REMODELING DESIGNERS

EXTERIOR ELEVATIONS -  
LEFT & RIGHT -  
WALKOUT BASEMENT

'NEW ERA'  
TOWNHOMES -  
PLAT 10  
ADDRESS T.B.D.

SPEC UNITS W/  
SUNROOM





# LEGACY TOWNHOMES - PLAT 10 SPEC UNITS W/ SUNROOM

ADDRESS T.B.D.

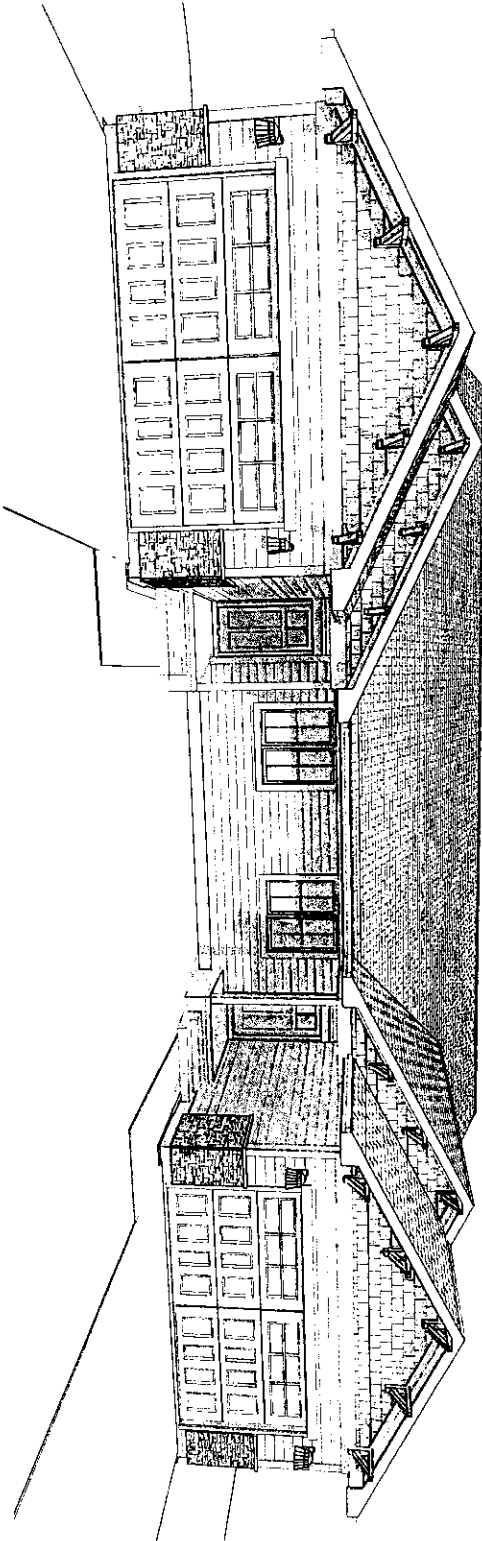

## AREA CHART

AREA SCHEDULE - FULL BASEMENT w/ SUNROOM			
BASEMENT	SQ. FT.	MAIN FLOOR	SQ. FT.
UTILITY STORAGE ROOM	617	CONDITIONED LIVING SPACE	1,669
STORAGE UNDER STAIRS	83	GARAGE	515
CONDITIONED LIVING SPACE w/ OPTIONAL FINISHED BASEMENT	834	PORCH DECK	28
TOTAL UNCOND. LIVING SPACE		1,669	
TOTAL UNCOND. SPACE		2,079	
TOTAL COND. LIVING SPACE w/ OPT. FINISHED BASEMENT		2,553	
TOTAL UNCONDITIONED SPACE w/ OPT. FINISHED BASEMENT		1,195	
TOTAL OUTDOOR SPACE		188	

AREA SCHEDULE - WALKOUT BASEMENT w/ SUNROOM			
BASEMENT	SQ. FT.	MAIN FLOOR	SQ. FT.
UTILITY STORAGE ROOM	617	CONDITIONED LIVING SPACE	1,669
STORAGE UNDER STAIRS	83	GARAGE	515
CONDITIONED LIVING SPACE w/ OPTIONAL FINISHED BASEMENT	916	PORCH WALKOUT STAIR	28
TOTAL UNCOND. LIVING SPACE		1,669	
TOTAL UNCOND. SPACE		2,111	
TOTAL COND. LIVING SPACE w/ OPT. FINISHED BASEMENT		2,595	
TOTAL UNCONDITIONED SPACE w/ OPT. FINISHED BASEMENT		1,195	
TOTAL OUTDOOR SPACE		172	

## SHEET INDEX - w/ SUNROOM

- 610 - COVER SHEET, PROJECT INFORMATION, AREA CHART, & SHEET INDEX
- 611 - GENERAL NOTES, VICINITY MAP, REVISION TABLE & ABBREVIATIONS
- A01 - BASEMENT / FOUNDATION PLAN - FULL BASEMENT
- A02 - BASEMENT / FOUNDATION PLAN - WALKOUT
- A11 - MAIN FLOOR PLAN - w/ FULL BASEMENT
- A12 - MAIN FLOOR PLAN - WALKOUT BASEMENT
- A01 - ROOF PLAN
- A31 - EXTERIOR ELEVATIONS - FRONT & REAR - FULL BASEMENT
- A32 - EXTERIOR ELEVATIONS - LEFT & RIGHT - FULL BASEMENT
- A33 - EXTERIOR ELEVATIONS - FRONT & REAR - WALKOUT BASEMENT
- A34 - EXTERIOR ELEVATIONS - LEFT & RIGHT - WALKOUT BASEMENT
- D1 - DETAILS & STAIR SECTION (WALL BE INCLUDED IN CONSTRUCTION DOCUMENT SET)

## PROJECT INFO

OWNER: NA  
 PROJECT ADDRESS: ADDRESS T.B.D.  
 LEGAL: .....  
 CODE ENFORCEMENT: XXX COUNTY, CITY OF XXX  
 WATER: .....  
 PERMIT: .....  
 DESIGNER: RESIDENTIAL + RENOVATING DESIGNS, LLC  
 BUILDER / CONTRACTOR: SQUAD BREAKER HOMES  
 ENGINEERING: NA  
 LANDSCAPE DESIGN: NA

PRICING SET - NOT FOR CONSTRUCTION

DRAWINGS PROVIDED BY:  
  
 RESIDENTIAL MODELING + DESIGN, LLC  
 DATE: 5/1/20  
 SHEET: 61.0

COVER SHEET, PROJECT INFORMATION, AREA CHART, & SHEET INDEX

LEGACY TOWNHOMES - PLAT 10 ADDRESS T.B.D.

SPEC UNITS W/ SUNROOM



# ABBREVIATIONS

- A** AIR CONDITIONING
- B** BATH
- C** CLOSET
- D** DRYER
- E** ELECTRICAL
- F** FLOOR
- G** GARAGE
- H** HALL
- I** INSULATION
- J** JOINT
- K** KITCHEN
- L** LAUNDRY
- M** MECHANICAL
- N** NORTH
- O** OPENING
- P** PORCH
- Q** QUARTER
- R** REAR
- S** SHOWER
- T** TERRACE
- U** UNDER
- V** VENT
- W** WINDOW
- X** EXTERIOR
- Y** YARD
- Z** ZONE

# REVISION TABLE

NUMBER	DATE	REVISION	DESCRIPTION

# VICINITY MAP

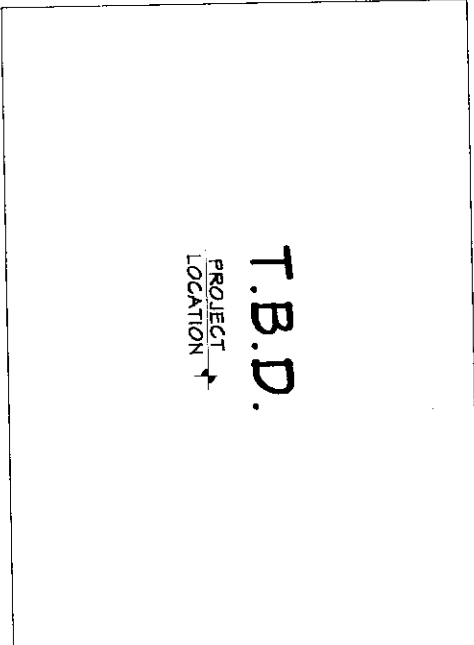

# GENERAL NOTES

- ALL WORK SHALL BE PERFORMED WITH ALL APPLICABLE LOCAL, STATE AND NATIONAL CODES AND ORDINANCES AND SHALL BE THE PROJECT DESIGNER'S JURISDICTION.
- THE CONTRACTOR SHALL VERIFY CONDITIONS AT THE SITE AND REPORT ANY DISCREPANCIES TO THE DESIGNER BEFORE PROCEEDING WITH THE WORK.
- THESE PLANS HAVE NOT BEEN CERTIFIED BY A STRUCTURAL ENGINEER.
- THESE PLANS INCLUDE LABOR, MATERIALS, TOOLS, EQUIPMENT, ETC.
- EACH CONTRACTOR SHALL INCLUDE LABOR, MATERIALS, TOOLS, EQUIPMENT, ETC. FOR THE COMPLETE CONSTRUCTION OF THE WORK, INDICATED AS SPECIFIED BY THE DRAWINGS AND SPECIFICATIONS, UNLESS OTHER ARRANGEMENTS HAVE BEEN MADE BETWEEN CONTRACTOR AND HOMEOWNER.
- MATERIALS AS SPECIFIED ON DRAWINGS AND CONTRACTUAL DOCUMENTS SHALL BE USED. THE CONTRACTOR SHALL BE RESPONSIBLE FOR ALL DETAILING AND COORDINATION IN CONSTRUCTION WITH SUBSTITUTIONS MADE TO SPECIFIC MATERIALS.
- DESIGNER'S RESPONSIBILITY DESIGNATIONS (RND) SHALL NOT BE RESPONSIBLE FOR CONSTRUCTION METHODS, METHODS, TECHNIQUES, SEQUENCES OR PROCEDURES, OR FOR SAFETY PRECAUTIONS AND PROGRAMS IN CONNECTION WITH THE WORK OR FOR THE ACTS OR OMISSIONS OF THE CONTRACTOR, SUB-CONTRACTORS, OR ANY OTHER PERSONS PERFORMING THE WORK OR FOR THE FAILURE OF ANY OF THEM TO CARRY OUT THE WORK IN ACCORDANCE WITH THE INTENT OF THE CONTRACT DOCUMENTS.
- ALL PLUMBING, MECHANICAL, AND ELECTRICAL WORK IS TO BE COMPLETED BETWEEN THE TRADES AS PART OF THEIR INSTALLATION LA SCOPE.
- CONTRACTOR SHALL PROVIDE ADEQUATE BRACING FOR CONSTRUCTION.
- ALL MATERIAL, FINISHES, EXTERIOR TRIM, AND INTERIOR AND EXTERIOR BRACING, ETC. SHALL BE APPROVED BY HOMEOWNER.
- DO NOT SCALE THE DRAWINGS. WRITTEN DIMENSIONS ALWAYS TAKE PRECEDENCE OVER SCALED DIMENSIONS.
- THE CONTRACTOR SHALL VERIFY ALL DIMENSIONS AND/OR DISCREPANCIES IN PLAN AND REPORT ERRORS TO RESIDENTIAL REVISIONS DESIGN (RND) PRIOR TO COMMENCEMENT OF THE WORK, AND TO BE RESPONSIBLE FOR CORRECTING THE SAME.
- PRIOR TO THE START OF CONSTRUCTION, THE CONTRACTOR SHALL VERIFY THE REQUIRED DESIGN LOADS WITH GOVERNING CODES, PERMITS, ORDINANCES, WITH THE LOCAL BUILDING AGENCIES AND/OR RESIDUAL REVISIONS DESIGN (RND) SHALL BE NOTIFIED OF ANY SUCH REQUIREMENTS.
- NOTICE OF A HILL, TREE NECESSARY PRECAUTIONS TO REMOVE OR RELocate ITEMS OF VALUE TO BE RECORDED AND OR SAVED, OR IN ANY DANGER OF BEING DAMAGED DUE TO CONSTRUCTION PROCESS.

# DIMENSIONS

- IN NO CASE SHALL WORKING DIMENSIONS BE SCALED FROM PLANS, SECTIONS, OR DETAILS ON DRAWINGS.
- ALL DIMENSIONS TO FINISHES ARE GOVERNED UNLESS NOTED OTHERWISE.
- CONTRACTOR TO STUDY PARTITIONS ARE TO THE FACE OF STUD UNLESS NOTED OTHERWISE.
- CEILING HEIGHT DIMENSIONS ARE FROM FLOOR SLEWING TO UNDERSIDE OF ROOF TRUSSES OR FLOOR JOIST.

# DETAILS

- DETAILS MARKED "TYPICAL" SHALL APPLY IN ALL CASES UNLESS NOTED OTHERWISE.
- WHERE NO SPECIFIC DETAIL IS SHOWN, THE FINISHES ON CONSTRUCTION SHALL BE IDENTICAL OR SIMILAR TO THAT INDICATED FOR THE CASES OF CONSTRUCTION ON THE PROJECT.
- FULLY DETAILED MANUFACTURERS, RECOMMENDED SPECIFICATIONS AND INSTALLATION METHODS SHALL BE PROVIDED BY THE CONTRACTOR.
- PROVIDE APPROPRIATE ANCHORAGE, BRACING, JACKING, AND FINISHES FOR LIGHT-FIXTURES, ELECTRICAL UNITS, HVAC EQUIPMENT, ETC.
- SCOUR ALL CONCRETE MAKES AWAY FROM EXTERIOR DOORS A MINIMUM OF 2% TO PREVENT WATER FROM RUNNING ON BEING BLOWN UNDER DOORWAYS AND TO PREVENT STANDING WATER FROM ACCUMULATING IN FRONT OF DOORS.
- REMOVE FINE BLOCKING AND DWAYT STOPPING IN SPACES CREATED BY CHAIRS, PLUMBING, ETC. IN ACCORDANCE WITH THE APPLICABLE CODES.
- SHOULDER ALARMS SHALL BE INSTALLED IN ACCORDANCE WITH THE APPLICABLE CODES.
- WHENEVER DESIGN INTENDS TO BE IN CONFLICT WITH ANY APPLICABLE CODES, IN REWARDS TO RESIDENTIAL REVISIONS DESIGN (RND) SHALL BE RESPONSIBLE FOR OBTAINING APPROVAL FROM MANUFACTURER TO ENSURE COMPLIANCE WITH APPLICABLE CODES.

PRICING SET - NOT FOR CONSTRUCTION

DATE: 5/11/20  
SHEET: 61.1

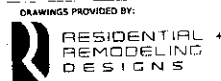

GENERAL NOTES, VICINITY MAP, REVISION TABLE, & ABBREVIATIONS

LEGACY TOWNHOMES - PLAT 10 ADDRESS T.B.D.

SPEC UNITS W/ SUNROOM





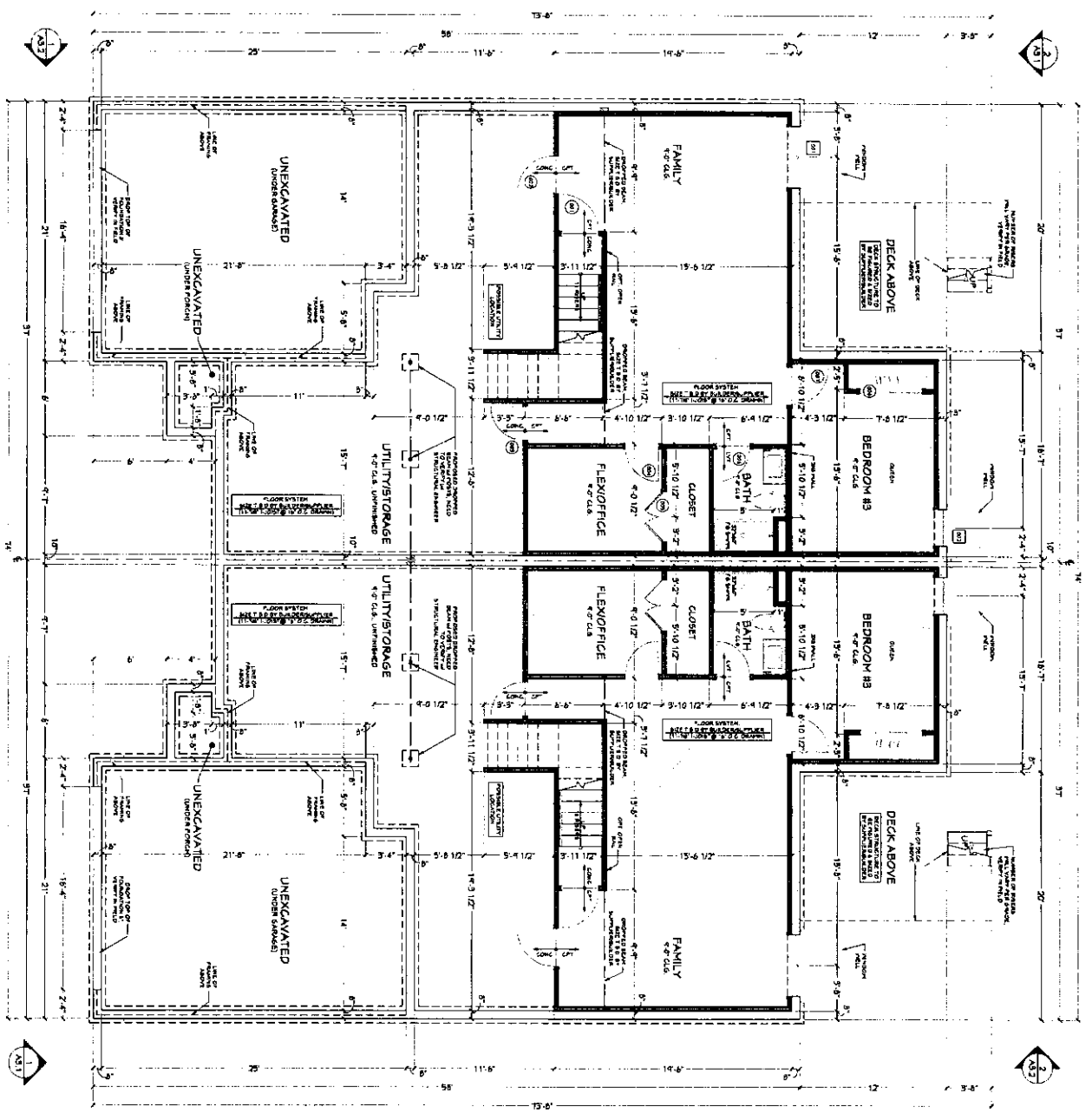

**FOUNDATION/BASEMENT NOTES**

- 1) Contractor to verify all dimensions prior to start of construction and resolve any concerns with Designer.
- 2) Contractor to verify floor codes that are applicable to this project.
- 3) These items have not been certified by a structural engineer.
- 4) Finish to be 3/4" x 8" slabs at 18" o.c. All wood framing to be Douglas Fir.
- 5) Interior walls to be 2 x 4 studs at 16" o.c. All wood framing to be Douglas Fir with 2nd story Substrate.
- 6) 2nd studs if retained or retained.
- 7) All PVC, Plumbing, and Electrical work to be designed by a professional engineer.
- 8) All wood in contact with earth or concrete to be treated with preservative.
- 9) Bathrooms without windows are required to have a window or exterior door.
- 10) All exterior doors shall be certified single egress as required by governing local codes. Hardwood smoke detectors with battery back-up required on each floor in sleeping areas.

**NOTE:**

- FINISH HEIGHT FOR BASEMENT LEVEL TO BE 8'-0"
- FINISH FLOORING FOR MAIN FLOOR TO BE 8'-0"

**WINDOW NOTES:**

EVERY WINDOW SHALL BE PROVIDED WITH AN EGRESS WINDOW WITH 1/2" MIN. SLIP RESISTANT AND SHALL HAVE AN AREA OF 5.7 SQ. FT. EGRESS WINDOW SHALL NOT HAVE AN OPENING AREA LESS THAN 5.7 SQ. FT. MIN.

NUMBER	NOTE	QUANTITY	UNIT	COMMENTS
001	DOOR	2	EA	
002	WINDOW	12	EA	
003	GLASS	12	SQ. FT.	
004	GLASS	12	SQ. FT.	
005	GLASS	48	SQ. FT.	
006	GLASS	24	SQ. FT.	
007	GLASS	24	SQ. FT.	
008	GLASS	24	SQ. FT.	
009	GLASS	24	SQ. FT.	
010	GLASS	24	SQ. FT.	
011	GLASS	24	SQ. FT.	
012	GLASS	24	SQ. FT.	
013	GLASS	24	SQ. FT.	
014	GLASS	24	SQ. FT.	
015	GLASS	24	SQ. FT.	
016	GLASS	24	SQ. FT.	
017	GLASS	24	SQ. FT.	
018	GLASS	24	SQ. FT.	
019	GLASS	24	SQ. FT.	
020	GLASS	24	SQ. FT.	

NUMBER	NOTE	QUANTITY	UNIT	COMMENTS
001	DOOR	2	EA	
002	WINDOW	12	EA	
003	GLASS	12	SQ. FT.	
004	GLASS	12	SQ. FT.	
005	GLASS	48	SQ. FT.	
006	GLASS	24	SQ. FT.	
007	GLASS	24	SQ. FT.	
008	GLASS	24	SQ. FT.	
009	GLASS	24	SQ. FT.	
010	GLASS	24	SQ. FT.	
011	GLASS	24	SQ. FT.	
012	GLASS	24	SQ. FT.	
013	GLASS	24	SQ. FT.	
014	GLASS	24	SQ. FT.	
015	GLASS	24	SQ. FT.	
016	GLASS	24	SQ. FT.	
017	GLASS	24	SQ. FT.	
018	GLASS	24	SQ. FT.	
019	GLASS	24	SQ. FT.	
020	GLASS	24	SQ. FT.	

AREA	SCHEDULE	QUANTITY	UNIT	COMMENTS
1	2018	1	EA	
2	2018	1	EA	
3	2018	1	EA	
4	2018	1	EA	
5	2018	1	EA	
6	2018	1	EA	
7	2018	1	EA	
8	2018	1	EA	
9	2018	1	EA	
10	2018	1	EA	
11	2018	1	EA	
12	2018	1	EA	
13	2018	1	EA	
14	2018	1	EA	
15	2018	1	EA	
16	2018	1	EA	
17	2018	1	EA	
18	2018	1	EA	
19	2018	1	EA	
20	2018	1	EA	

**BASEMENT / FOUNDATION PLAN - FULL BASEMENT**  
SCALE: 3/8"=1'-0"

PRICING SET - NOT FOR CONSTRUCTION

DATE: 5/1/20  
SHEET: A0.1



**BASEMENT / FOUNDATION PLAN - FULL BASEMENT**

**'LEGACY' TOWNHOMES - PLAT 10**  
ADDRESS T.B.D.

**SPEC UNITS W/ SUNROOM**





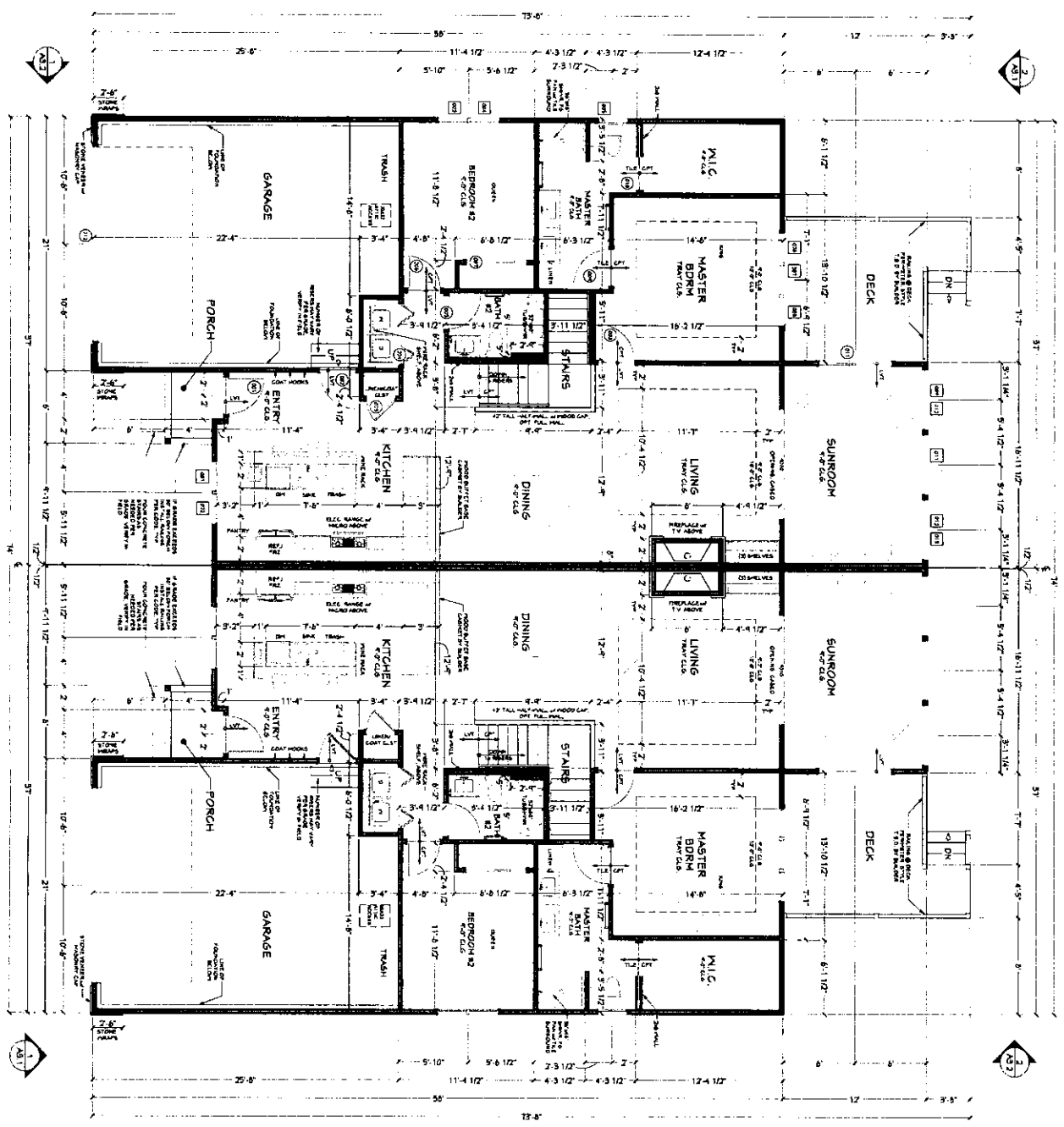

1  
**MAIN FLOOR PLAN -  
 w/ FULL BASEMENT**  
 SCALE: 2/8" = 1'-0"

AREA SCHEDULE	
FULL BASEMENT	327.77
STAIRS	11.11
LANDING	1.11
TRASH	1.11
ENTRY	1.11
KITCHEN	1.11
DINING	1.11
LIVING	1.11
SUNROOM	1.11
MASTER BDRM	1.11
2ND BDRM	1.11
BATH	1.11
PORCH	1.11
GARAGE	1.11
<b>TOTAL CONCRETE</b>	<b>1,884</b>
<b>TOTAL CONCRETE</b>	<b>2,078</b>
<b>TOTAL UNCONDITIONED SPACE</b>	<b>1,149</b>
<b>TOTAL UNCONDITIONED SPACE</b>	<b>150</b>

NUMBER	DESCRIPTION	UNIT	QUANTITY	REMARKS
001	CONCRETE	sq ft	1,884	
002	FORMWORK	sq ft	3,768	
003	REINFORCING	lbs	15,000	
004	STEEL	sq ft	1,149	
005	GLASS	sq ft	1,149	
006	WOOD	sq ft	1,149	
007	PAINT	sq ft	1,149	
008	ROOFING	sq ft	1,149	
009	MECHANICAL	sq ft	1,149	
010	ELECTRICAL	sq ft	1,149	
011	PLUMBING	sq ft	1,149	
012	FINISHES	sq ft	1,149	
013	LANDSCAPE	sq ft	1,149	
014	EXTERIOR	sq ft	1,149	
015	INTERIOR	sq ft	1,149	
016	MECHANICAL	sq ft	1,149	
017	ELECTRICAL	sq ft	1,149	
018	PLUMBING	sq ft	1,149	
019	FINISHES	sq ft	1,149	
020	LANDSCAPE	sq ft	1,149	

NUMBER	DESCRIPTION	UNIT	QUANTITY	REMARKS
001	CONCRETE	sq ft	1,884	
002	FORMWORK	sq ft	3,768	
003	REINFORCING	lbs	15,000	
004	STEEL	sq ft	1,149	
005	GLASS	sq ft	1,149	
006	WOOD	sq ft	1,149	
007	PAINT	sq ft	1,149	
008	ROOFING	sq ft	1,149	
009	MECHANICAL	sq ft	1,149	
010	ELECTRICAL	sq ft	1,149	
011	PLUMBING	sq ft	1,149	
012	FINISHES	sq ft	1,149	
013	LANDSCAPE	sq ft	1,149	
014	EXTERIOR	sq ft	1,149	
015	INTERIOR	sq ft	1,149	
016	MECHANICAL	sq ft	1,149	
017	ELECTRICAL	sq ft	1,149	
018	PLUMBING	sq ft	1,149	
019	FINISHES	sq ft	1,149	
020	LANDSCAPE	sq ft	1,149	

**FLOOR PLAN NOTES:**

- 1) Contractor to verify all dimensions prior to start of construction and resolve any concerns with Designer and/or Owner.
- 2) Contractor to verify local codes that are applicable to this project and conduct as in 3) These items have not been verified by a structural engineer.
- 3) Exterior and interior walls to be 2 x 4 studs @ 16" o.c. unless noted otherwise. All wood shall be pressure treated for ground contact.
- 4) Exterior and interior walls to be 2 x 4 studs @ 16" o.c. unless noted otherwise. All wood shall be pressure treated for ground contact.
- 5) All doors to be 2 1/2" thick with 2nd grade Schedule 240 slabs of double or needed.
- 6) Double floor joists under parallel walls located above.
- 7) All structural steel to be A36, minimum 1/4" thick and all steel to be galvanized.
- 8) Steel to be galvanized and all steel to be galvanized.
- 9) All steel to be galvanized and all steel to be galvanized.
- 10) All steel to be galvanized and all steel to be galvanized.
- 11) All steel to be galvanized and all steel to be galvanized.
- 12) All steel to be galvanized and all steel to be galvanized.
- 13) All steel to be galvanized and all steel to be galvanized.
- 14) All steel to be galvanized and all steel to be galvanized.
- 15) All steel to be galvanized and all steel to be galvanized.

**NOTE:**

ALL DIMENSIONS ARE IN FEET AND INCHES UNLESS NOTED OTHERWISE.

**WINDOW NOTES:**

EVERY WINDOW SHALL BE PROVIDED WITH AN OPERABLE WINDOW HANDLE AND SHALL HAVE A MINIMUM OPERABLE AREA OF 57 SQUARE FEET PER WINDOW.

PRICING SET - NOT FOR CONSTRUCTION

SHEET: A1.1

DATE: 5/1/20

DRAWINGS PROVIDED BY: RESIDENTIAL REMODELING DESIGN

MAIN FLOOR PLAN - w/ FULL BASEMENT

'LEGACY' TOWNHOMES - PLAT 10 ADDRESS T.B.D.

SPEC UNITS w/ SUNROOM





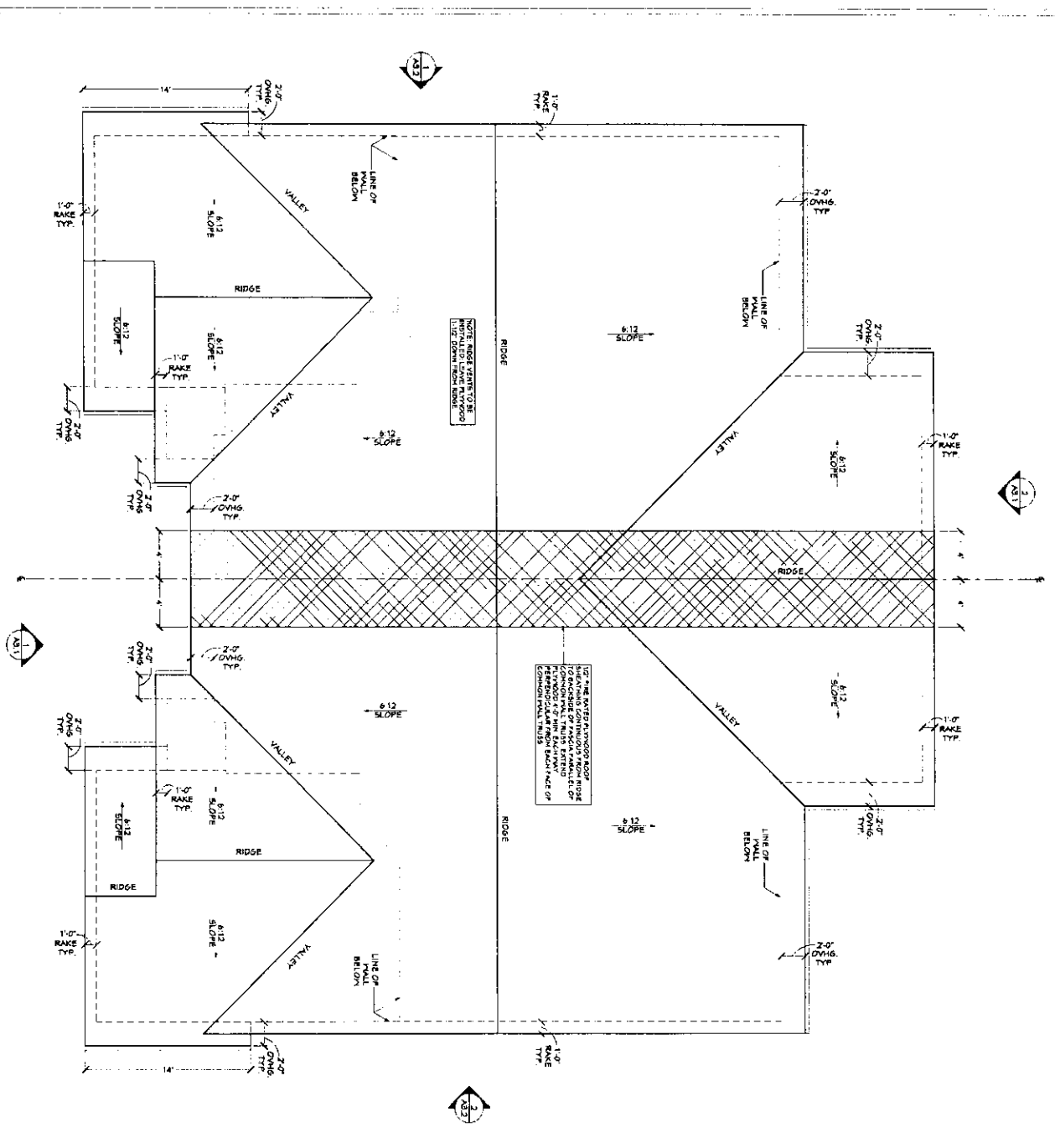

1 ROOF PLAN  
SCALE: 24x36 (1/4"=1'-0")

AREA SCHEDULE		FULL BASEMENT SUNROOM	
ROOF	617	CONCRETE	1,844
UNDERLAY	48	RAVINE	518
UNDERLAY	44	RAVINE	20
UNDERLAY	44	RAVINE	140
TOTAL UNDER SPACE		1,864	
TOTAL CONCRETE SPACE		2,078	
TOTAL UNFINISHED BASEMENT		2,955	
TOTAL FINISHED BASEMENT		1,145	
TOTAL CONCRETE SPACE		1,289	

- ROOF PLAN
- 1) Contractor to verify all dimensions prior to start of work.
  - 2) Contractor to verify local codes that are applicable to this project and confirm all in compliance with these codes.
  - 3) Contractor to verify all dimensions and confirm all in compliance with these codes.
  - 4) Total manufacturer to size members, fasteners, and all loads per manufacturer's specifications.
  - 5) Manufacturer to provide all dimensions and confirm all in compliance with these codes.
  - 6) All roof rakes are 12" unless noted otherwise.
  - 7) All roof rakes are 12" unless noted otherwise.
  - 8) All roof rakes are 12" unless noted otherwise.
  - 9) Treat all access points of 22" x 30" minimum with 30" underlayment and confirm all in compliance with these codes.
  - 10) Contractor to verify all dimensions and confirm all in compliance with these codes.

PRICING SET - NOT FOR CONSTRUCTION

SHEET: A2.1

DATE: 5/1/20

DRAWINGS PROVIDED BY:  
CONFIDENTIAL +  
REMODELING  
INCORPORATED

ROOF PLAN

LEGACY  
TOWNHOMES -  
FLAT 10  
ADDRESS T.B.D.

SPEC UNITS W/  
SUNROOM



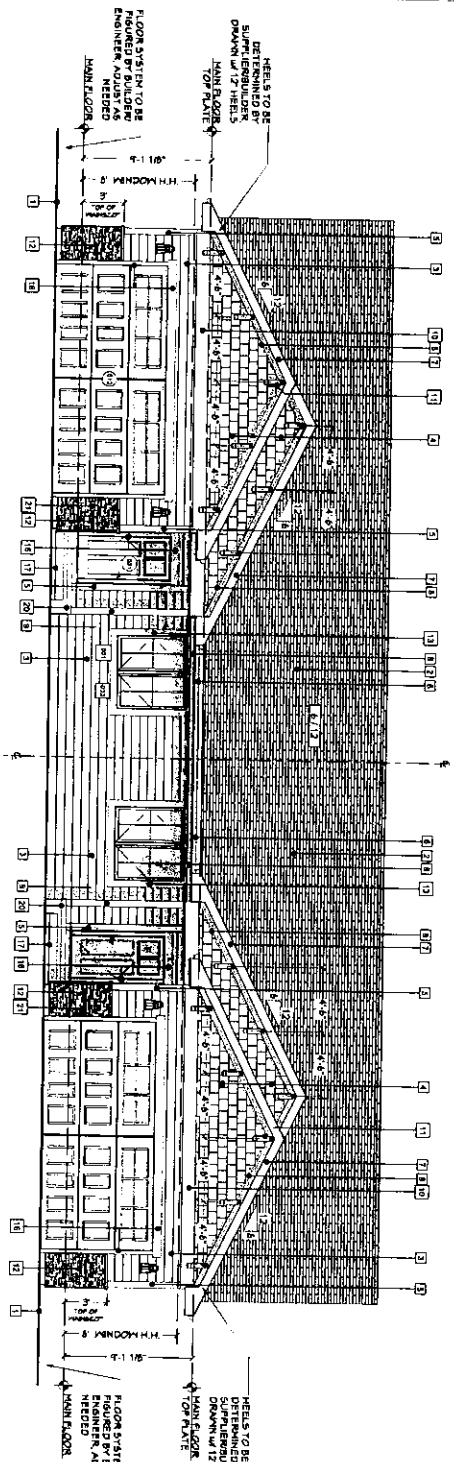

1 FRONT ELEVATION  
SCALE: 24x36 (1/4"=1'-0")  
12x18 (1/8"=1'-0")

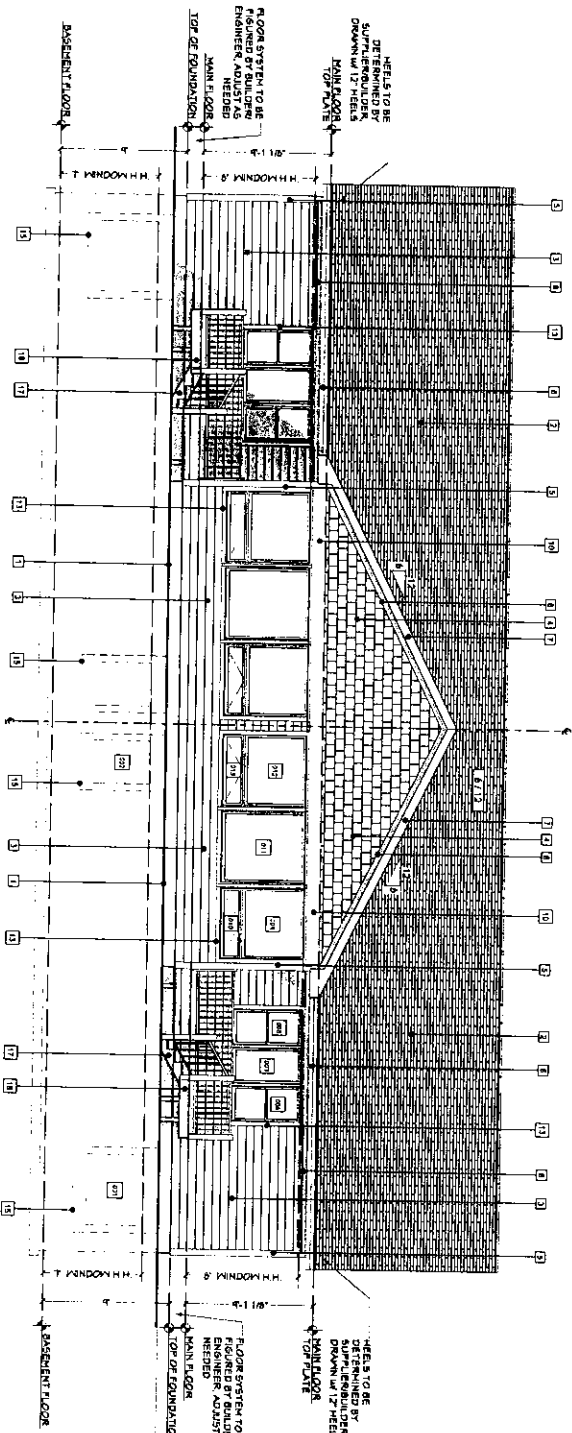

2 REAR ELEVATION - FULL BASEMENT  
SCALE: 24x36 (1/4"=1'-0")  
12x18 (1/8"=1'-0")

1	ELEVATION NOTE: SCHEDULE FROM ABOVE. SLOPE AWAY FROM FLOOR.
2	ASPHALT/COMPOSITE SHINGLES
3	LAP SIDING, PAINTED FIBER (GREEN T/CR LANCIE)
4	SHANK SIDING, PAINTED FIBER (GREEN T/CR LANCIE)
5	1x6 CORNER BOARD, TYP.
6	1x6 FASCIA
7	1x8 RAKE
8	1x6 FRIEZE BOARD
9	6x6 WOOD POST
10	1x12 BAND BOARD
11	CABLE BRACKET, 18"x18"x4"
12	MANUFACTURED STONE VENEER
13	WINDOW TRIM: 1x4 JAMB, 1x6 HEAD TRIM, 1x4 JAMB, 1x6 HEAD TRIM TO FRIEZE/RAND BOARD
14	WINDOW TRIM: 1x4 JAMB, 1x6 HEAD TRIM
15	WINDOW WELL
16	DOOR TRIM: 1x4 JAMB, 1x8 HEAD TRIM, DOOR PER BUILDER
17	STAIRS, BUILD TO GRADE, V.I.F.
18	WOOD DECK w/ RAILING, STYLE T.B.D. BY BUILDER
19	CONCRETE STOOP
20	CONCRETE STOOP
21	LIGHT FIXTURE, EXTERIOR

\*ALL ELEVATIONS & SECTIONS HAVE BEEN DRAWN WITH AN 11.25' LIGHT FLOOR SYSTEM @ MAIN FLOOR. THESE DRAWINGS HAVE NOT BEEN REVIEWED BY A STRUCTURAL ENGINEER. FLOOR SYSTEM IS SUBJECT TO CHANGE UPON REVIEW BY STRUCTURAL ENGINEER AND/OR BUILDER.

PRICING SET - NOT FOR CONSTRUCTION

SHEET: A3.1

DATE: 5/17/20

DRAWINGS PROVIDED BY:  
**RESIDENTIAL REMODELING DESIGNS**

EXTERIOR ELEVATIONS - FRONT & REAR - FULL BASEMENT

LEGACY TOWNHOMES - PLAT 10 ADDRESS T.B.D.

SPEC UNITS W/ SUNROOM



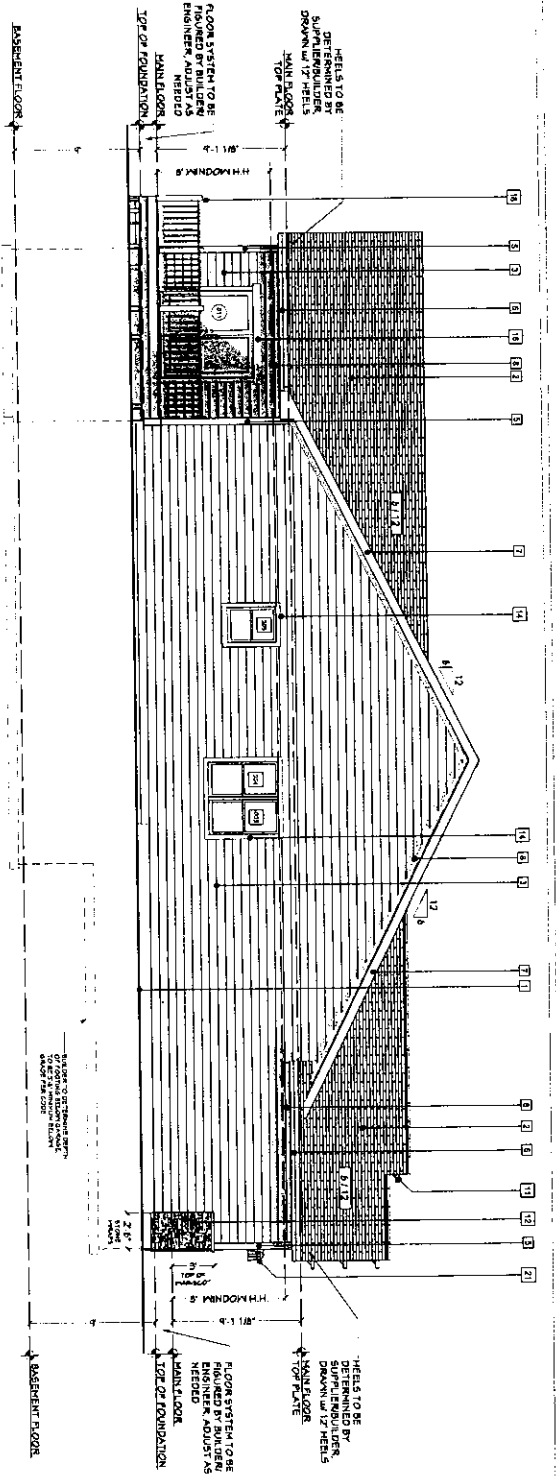

1 LEFT ELEVATION - FULL BASEMENT  
SCALE: 24x36 (1/4"=1'-0")  
12x18 (1/8"=1'-0")

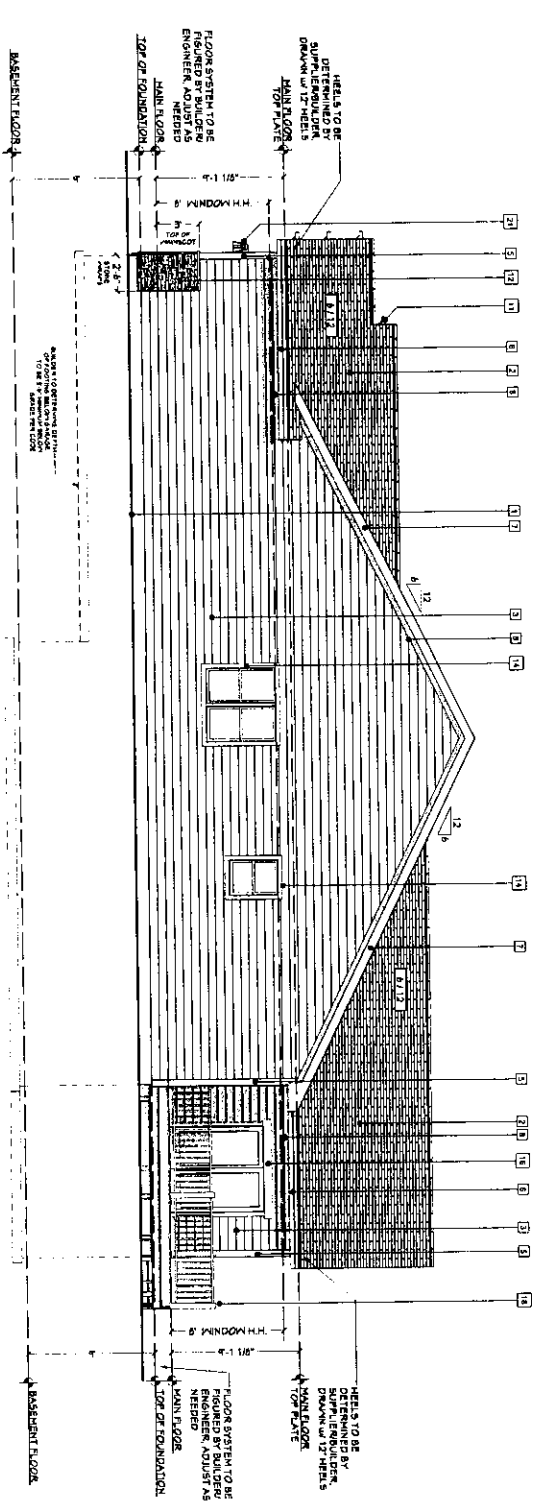

2 RIGHT ELEVATION - FULL BASEMENT  
SCALE: 24x36 (1/4"=1'-0")  
12x18 (1/8"=1'-0")

1	Elevation Note Schedule
2	1/8" GABLE, SHORE AWAY FROM HOUSE
3	ASPHALT/COMPOSITE SHINGLES
4	LAP SIDING, PAINTED FIBER
5	CEMENT LIP OR HARDIE FIBER
6	CEMENT LIP OR HARDIE
7	1/8" CORNER BOARD, TYP
8	1/8" FASCIA
9	1/8" RAKE
10	1/8" FRIEZE BOARD
11	6x8 WOOD POST
12	1x12 BAND BOARD
13	CABLE BRACKET, 18"x18"x4"
14	MANUFACTURED STONE VENEER
15	MANUFACTURED STONE VENEER
16	WINDSOR TRIM, 1x4 JAMB & SILL w/ 1x12 HEAD TRIM TO FREEZEBOARD
17	WINDOW FRM, 1x4 JAMB, SILL & HEAD TRIM
18	WINDOW WELL
19	DOOR TRIM, 1x4 JAMB w/ 1x8 HEAD TRIM, DOOR PER BUILDER
20	STAIRS, BUILD TO GRADE V.I.F.
21	WOOD DECK w/ RAILING, STYLE TBD BY BUILDER
22	T.O.D. BY BUILDER
23	CONCRETE STOOP
24	LIGHT FIXTURE, EXTERIOR

\* ALL ELEVATIONS & SECTIONS HAVE BEEN DRAWN WITH AN 1/8" LINE WEIGHT. THESE DRAWINGS HAVE NOT BEEN REVIEWED BY A STRUCTURAL ENGINEER. A COLOR SYSTEM IS SUBJECT TO CHANGE. CONSULT STRUCTURAL ENGINEER AND/OR BUILDER.

PRICING SET - NOT FOR CONSTRUCTION

SHEET: A3.2

DATE: 5/1/20  
DRAWINGS PROVIDED BY: RESIDENTIAL + REMODELING DESIGNS

EXTERIOR ELEVATIONS - LEFT & RIGHT - FULL BASEMENT

LEGACY TOWNHOMES - PLAT 10 ADDRESS T.B.D.

SPEC UNITS W/ SUNROOM



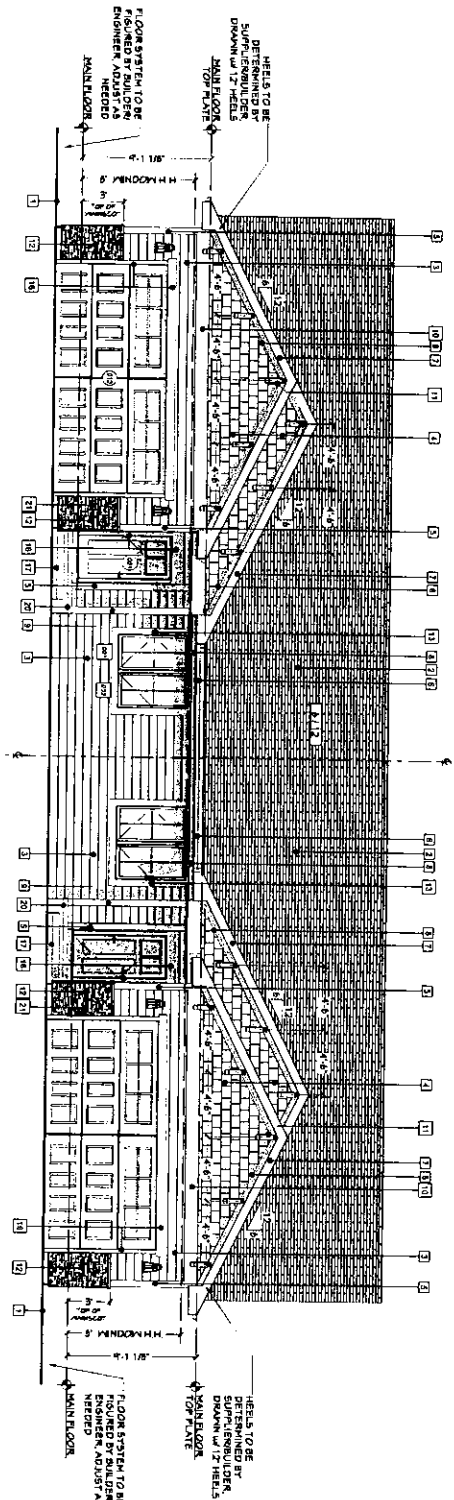

1 FRONT ELEVATION  
SCALE: 2/8"=1'-0"  
1/2"=1'-0"

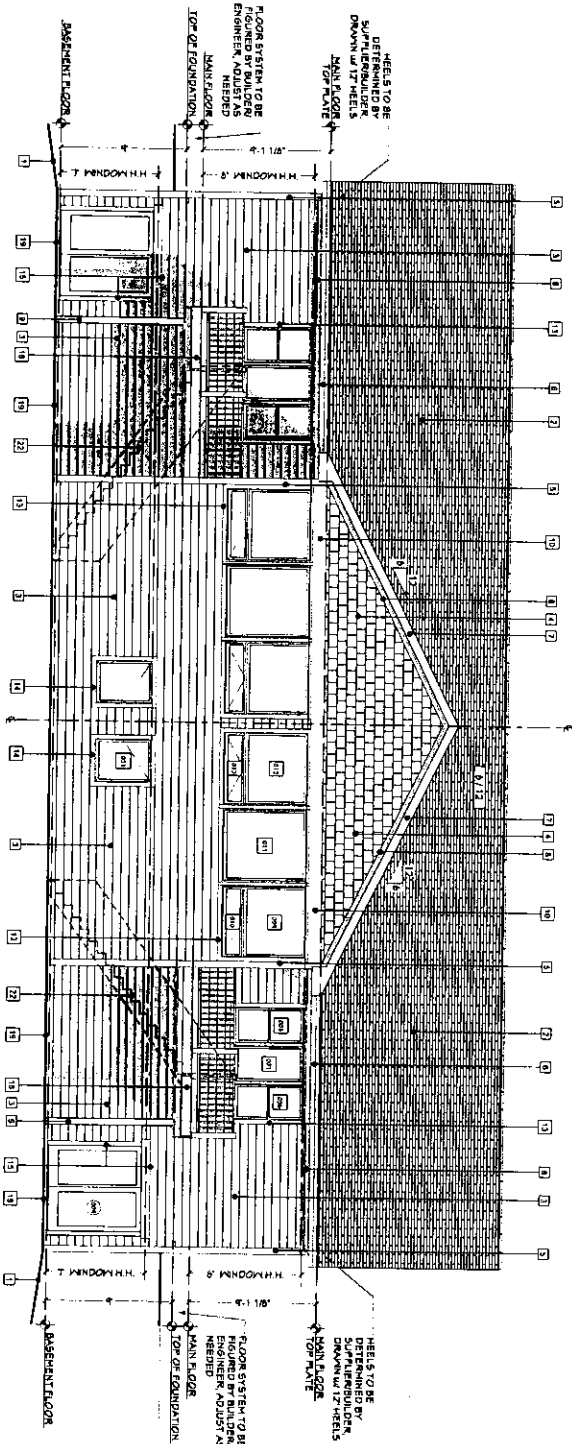

2 REAR ELEVATION -  
WALKOUT BASEMENT  
SCALE: 2/8"=1'-0"  
1/2"=1'-0"

\* ALL ELEVATIONS & SECTIONS HAVE BEEN DRAWN WITH AN 1/8" TOLERANCE SYSTEM @ MAIN FLOOR. THESE DRAWINGS HAVE NOT BEEN REVIEWED BY A PROFESSIONAL ENGINEER. FLOOR SYSTEMS SHALL BE SUBJECT TO THE REVIEW OF STRUCTURAL ENGINEER AND/OR BUILDER.

1	LINE OF GRADE - SLOPE AWAY FROM HOUSE
2	ASPHALT/COMPOSITE SHINGLES
3	1/2" SIDING PAINTED FIBER
4	SHAKE SIDING PAINTED FIBER CEMENT (L.P. OR HARDEL)
5	1/4" CORNER BOARD, TYP.
6	1/4" FASCIA
7	1/4" RAKE
8	1/4" FRIEZE BOARD
9	6/8" WOOD POST
10	1x2 BOARD BOARD
11	GABLE BRACKET 18"X18"X4"
12	TEXTURED/PAINTED STONE VENEER CONCRETE OR MASONRY STONE CAP
13	WINDOW TRIM, 1x4 JAMB & SILL w/ 1x1 HEAD TRIM TO FREEZEBOARD BOARD
14	WINDOW TRIM, 1x4 JAMB, SILL & HEAD
15	DOOR TRIM, 1x4 JAMB w/ 1x4 DOOR TRIM, 1x4 JAMB w/ 1x4 HEAD TRIM, DOOR PER BUILDER
16	HEAD TRIM, DOOR PER BUILDER
17	WOOD DECK w/ RAILING STYLE T.B.D. BY BUILDER
18	PATIO
19	CONCRETE STOOP
20	CONCRETE STOOP
21	LIGHT FIXTURE, EXTERIOR
22	OPTIONAL STAIRS w/ WALKOUT OPTION, BUILD TO GRADE, V.I.F.

PRICING SET - NOT FOR CONSTRUCTION

DRAWINGS PROVIDED BY:  
**RESIDENTIAL REMODELING DESIGNS**  
 DATE: 5/1/20  
 SHEET: A3.3

EXTERIOR ELEVATIONS -  
FRONT & REAR -  
WALKOUT BASEMENT

LEGACY TOWNHOMES -  
PLAT 10  
ADDRESS T.B.D.

SPEC UNITS W/  
SUNROOM





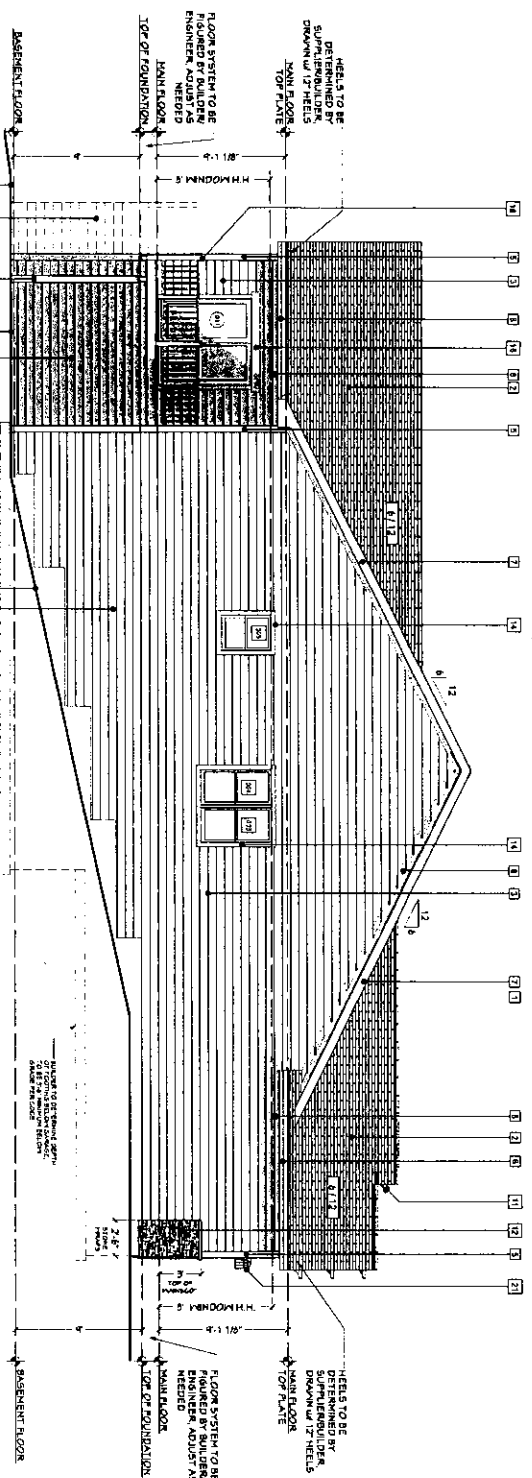

1 LEFT ELEVATION -  
WALKOUT BASEMENT  
SCALE: 2x/8x6 (1/4"=1'-0")  
12x18 (1/8"=1'-0")

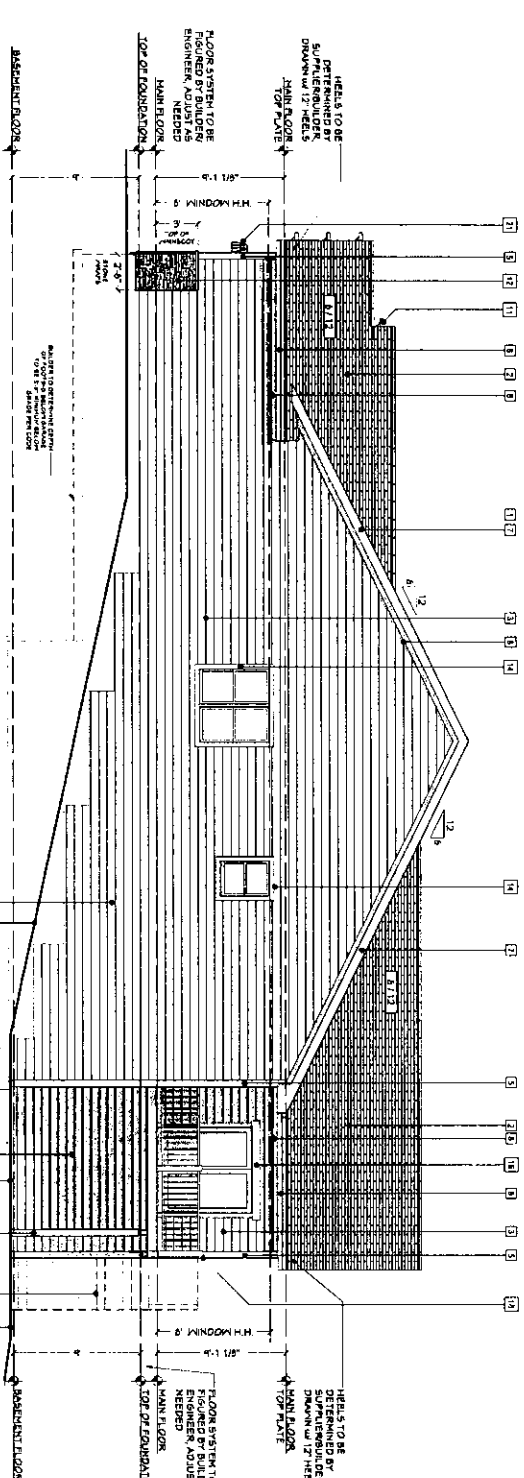

2 RIGHT ELEVATION -  
WALKOUT BASEMENT  
SCALE: 2x/8x6 (1/4"=1'-0")  
12x18 (1/8"=1'-0")

Item #	Description
1	ELEVATION NOTE SCHEDULE
2	FINDING HOUSE ... SLOPE AWAY
3	ASPHALT/COMPOSITE SHINGLES
4	LAP SIDING, PAINTED FIBER CEMENT (LP OR HARDIE) SHEATHING (OR HARDIE) GEMERL (OR HARDIE)
5	1x6 CORNER BOARD, TYP.
6	1x6 FASCIA
7	1x8 RAKE
8	1x6 FRIEZE BOARD
9	6x6 WOOD POST
10	1x12 BAND BOARD
11	GABLE BRACKET, 18"x18"x4"
12	MANUFACTURED STONE VENEER
13	WINDOW TRIM, 1x4 JAMB & SILL w/ 1x HEAD TRIM TO PRIZEER/BAND BOARD
14	WINDOW TRIM, 1x4 JAMB, SILL, & HEAD TRIM
15	HEAD TRIM, 1x4 JAMB, SILL, & DOOR TRIM, 1x4 JAMB, SILL, & HEAD TRIM, DOOR PER BUILDER
16	HEAD TRIM, DOOR PER BUILDER
17	STAIRS, BUILD TO GRADE, V.I.F.
18	WOOD DECK w/ RAILING, STYLE TBD BY BUILDER
19	PATIO
20	CONCRETE STOOP
21	LIGHT FIXTURE, EXTERIOR
22	OPTIONAL STAIRS w/ WALKOUT OPTION, BUILD TO GRADE, V.I.F.

ALL ELEVATIONS & SECTIONS HAVE BEEN DRAWN WITH AN 11 7/8" LAYOUT FLOOR SYSTEM @ MAIN FLOOR. THESE DRAWINGS HAVE NOT BEEN REVIEWED BY A STRUCTURAL ENGINEER. FLOOR SYSTEM IS SUBJECT TO CHANGE UPON REVIEW OF STRUCTURAL ENGINEER AND/OR BUILDER.

PRICING SET - NOT FOR CONSTRUCTION

DATE: 5/17/20 SHEET: A3.4	DRAWINGS PROVIDED BY: <b>RESIDENTIAL + REMODELING DESIGN</b>	EXTERIOR ELEVATIONS - LEFT & RIGHT - WALKOUT BASEMENT	LEGACY TOWNHOMES - PLAT 10 ADDRESS T.B.D.	SPEC UNITS W/ SUNROOM 
------------------------------	---	---	---	---------------------------

**EXHIBIT "D"**  
**UNDIVIDED FRACTIONAL OWNERSHIP INTEREST IN THE LAND  
AND COMMON ELEMENTS  
AND  
ALLOCATION OF VOTES IN THE ASSOCIATION**

UNIT #	LOT #	STREET ADDRESS	UNDIVIDED FRACTIONAL OWNERSHIP INTEREST	NUMBER OF VOTES
100	1	810 Trail Ridge Ave, Indianola, IA 50125	1/20	1
101	1	812 Trail Ridge Ave, Indianola, IA 50125	1/20	1
200	2	814 Trail Ridge Ave, Indianola, IA 50125	1/20	1
201	2	816 Trail Ridge Ave, Indianola, IA 50125	1/20	1
300	3	818 Trail Ridge Ave, Indianola, IA 50125	1/20	1
301	3	820 Trail Ridge Ave, Indianola, IA 50125	1/20	1
400	4	822 Trail Ridge Ave, Indianola, IA 50125	1/20	1
401	4	824 Trail Ridge Ave, Indianola, IA 50125	1/20	1
500	5	826 Trail Ridge Ave, Indianola, IA 50125	1/20	1
501	5	828 Trail Ridge Ave, Indianola, IA 50125	1/20	1
600	6	825 Trail Ridge Ave, Indianola, IA 50125	1/20	1
601	6	827 Trail Ridge Ave, Indianola, IA 50125	1/20	1
700	7	821 Trail Ridge Ave, Indianola, IA 50125	1/20	1
701	7	823 Trail Ridge Ave, Indianola, IA 50125	1/20	1
800	8	817 Trail Ridge Ave, Indianola, IA 50125	1/20	1
801	8	819 Trail Ridge Ave, Indianola, IA 50125	1/20	1
900	9	813 Trail Ridge Ave, Indianola, IA 50125	1/20	1
901	9	815 Trail Ridge Ave, Indianola, IA 50125	1/20	1
1000	10	809 Trail Ridge Ave, Indianola, IA 50125	1/20	1
1001	10	811 Trail Ridge Ave, Indianola, IA 50125	1/20	1
N/A	Appurtenant to each Unit is an undivided 1/20 <sup>th</sup> fractional ownership interest in Outlot Z of Heritage Hills Plat 10, which shall pass as a General Common Element in conjunction with the ownership of each respective Unit at the time of conveyance without the necessity of naming the same.			



**EXHIBIT "E"**  
**ARTICLES OF INCORPORATION AND BYLAWS**



ARTICLES OF INCORPORATION

OF

**HERITAGE HILLS VILLAGE TOWNHOMES ASSOCIATION, INC.**

**TO THE SECRETARY OF STATE OF THE STATE OF IOWA:**

The undersigned, acting as incorporator of a corporation under the provisions of the Revised Iowa Nonprofit Corporation Act, Chapter 504 of the Code of Iowa, adopts the following Articles of Incorporation for such corporation.

**ARTICLE I. NAME**

The name of the corporation is Heritage Hills Village Townhomes Association, Inc.

**ARTICLE II. CORPORATE EXISTENCE**

The corporate existence of this corporation shall begin on the date these Articles of Incorporation are filed with the Secretary of State of the State of Iowa and shall continue perpetually thereafter unless dissolved as provided by law.

**ARTICLE III. PURPOSES AND POWERS**

The corporation is organized and shall operate as a "Homeowners Association" within the meaning of Section 528 of the Internal Revenue Code of 1986, as amended. The primary purpose of the corporation is to own, operate and maintain certain common property situated in Indianola, Warren County, Iowa, for and on behalf of the co-owners of the property described in the Declaration of Submission of Property to Horizontal Property Regime for Heritage Hills Village Townhomes, created and submitted pursuant to the provision of Chapter 499B of the Code of Iowa, as amended.

The corporation shall have all powers and purposes granted or implied to a council of co-owners under the provisions of Chapter 499B, Code of Iowa, and as are granted or implied by the Declaration of Condominium establishing the Condominium Regime, and all of such powers shall likewise constitute lawful purposes of the corporation.

The purposes of the corporation are exclusively not for private profit or gain. No part of the net earnings shall inure to the benefit of, or be distributed to, any member, director or officer of the corporation or other private individual, except that reasonable compensation may be paid for services rendered to or for the corporation affecting one or more of its purposes. No part of its activities shall consist of carrying on political propaganda or otherwise attempting to influence legislation, and the Association shall not participate in, or intervene in (including the publishing or distribution of statements) any political campaign on behalf of or in opposition to any candidate for public office.



As a means of accomplishing the foregoing purposes, the corporation shall have all of the general powers set forth in Chapter 504 of the Code of Iowa, and as it may hereafter be amended. These general powers shall be exercised exclusively for the attainment of the purposes of the corporation as set forth in this Article.

#### **ARTICLE IV. DISSOLUTION PROVISIONS**

Upon the dissolution of the corporation, the Board of Directors shall, after paying or making provisions for the payment of all of the liabilities of the corporation, dispose of all of the remaining assets of the corporation to a local government for a public purpose or to those nonprofit associations or organizations operated exclusively as associations or organizations with a similar purpose. Any such assets not so disposed of shall be disposed of by the District Court of the County in which the principal office of the corporation is then located to such associations or organizations, as said Court shall determine, which are organized and operated exclusively for similar purposes.

#### **ARTICLE V. INITIAL REGISTERED OFFICE AND REGISTERED AGENT**

The address of its initial registered office in the State of Iowa is 12119 Stratford Drive, Suite B, Clive, Iowa 50325 and the name of its initial registered agent at such address is Steve Bruere.

#### **ARTICLE VI. INITIAL BOARD OF DIRECTORS**

The number of Directors constituting the initial Board of Directors of the corporation is one (1). The number of Directors may be changed by the Board of Directors upon the adoption of Bylaws for the corporation and by any subsequent amendment to the Bylaws adopted by the Board of Directors. The name of the person who is to serve as the initial Director is Steve Bruere.

#### **ARTICLE VII. MEMBERS**

The corporation shall have members. The designation of membership classes, the manner of election and the qualifications and rights of the members of each class shall be as set forth in the Bylaws of the corporation.

#### **ARTICLE VIII. EXEMPTION OF PRIVATE PROPERTY**

Consistent with Section 504.901 of the Code of Iowa, the private property of directors, officers, employees, or members of a corporation shall be exempt from all debts, obligations, or liabilities of the corporation of any kind whatsoever and directors, officers, members and other volunteers of this corporation shall not be personally liable in that capacity to any person for any action taken or failure to take any action in the discharge of the person's duties except liability for (i) the amount of any financial benefit to which the person is not entitled; (ii) an intentional infliction of harm on the corporation or the members; (iii) violation of Section 504.834 of the Code



of Iowa; or (iv) the intentional violation of criminal law. If Iowa law is hereafter changed to mandate or permit further elimination or limitation of the liability of the corporation's directors, officers, employees, members and volunteers, then the liability of the corporation's directors, officers, employees, members and volunteers shall be eliminated or limited to the full extent then permitted.

#### **ARTICLE IX. INCORPORATOR**

The name and address of the Incorporator is Jacob M. Oeth, Hogan Law Office, 3101 Ingersoll Avenue, Suite 103, Des Moines, Iowa 50312.

#### **ARTICLE X. AMENDMENTS**

These Articles of Incorporation may be amended at any time and from time to time as provided by the Code of Iowa, but no amendment shall be adopted which deprives the corporation of tax exempt status under the Internal Revenue Code of 1986, as amended.

Dated June 18, 2020.

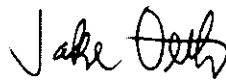

---

JACOB M. OETH, Incorporator



BYLAWS  
OF  
**HERITAGE HILLS VILLAGE TOWNHOMES ASSOCIATION, INC.**

**ARTICLE I. PURPOSES**

Heritage Hills Village Townhomes Association, Inc. (the "Association") will conduct its activities to promote the purposes for which it was organized as set forth in its Articles of Incorporation. No substantial part of the activities of the Association shall be the carrying on of propaganda, or otherwise attempting to influence legislation, and the Association shall not participate in, or intervene in (including the publishing or distribution of statements) any political campaign on behalf of or in opposition to any candidate for public office. Notwithstanding any other provisions of these Bylaws, the Association shall not carry on any activities not permitted to be carried on by a corporation exempt from federal income tax under Section 528 of the Internal Revenue Code (or the corresponding provision of any future United States Internal Revenue Law).

**ARTICLE II. OFFICES**

Section 2.1 Principal Office. The principal office of the Association in the State of Iowa shall be located in the City of Clive, Polk County, Iowa. The Association may have such other offices, either within or without the State of Iowa as the Board of Directors may designate or as the business of the Association may require from time to time.

Section 2.2 Registered Office. The registered office of the Association in the State of Iowa may be, but need not be, identical with the principal office in the State of Iowa, and the address of the registered office may be changed from time to time by the Board of Directors.

**ARTICLE III. MEMBERSHIP**

Section 3.1 Members. Every Unit Owner in Heritage Hills Village Townhomes subject to the Declaration of Submission of Property to Horizontal Property Regime for Heritage Hills Village Townhomes, as the same may be amended from time to time (collectively, the "Declaration") shall be a Member of the Association. When more than one person holds an interest in any Unit, all such persons shall be Members. Membership shall be appurtenant to and may not be separated from ownership of any Unit that is subject to assessment set forth in the Declaration. Ownership of a Unit shall be the sole qualification for membership.

Section 3.2 Voting. Ground Breaker Homes, LLC, an Iowa limited liability company (the "Declarant"), shall be the only Member of the Association entitled to vote for so long as it holds title to any Unit or until it waives or assigns, in writing, its right to be the sole voting member. Thereafter, the owners of a Unit shall be entitled to one vote for each Unit owned. The vote for each Unit shall be exercised as the owners of the Unit, among themselves, determine, but in no event shall more than one vote be cast with respect to any Unit.



Section 3.3 Suspension of Voting Rights. The Association shall suspend the voting rights of a Member for any period during which any assessment against the Member's Unit remains unpaid. The Association may suspend the voting rights of a Member for a period not to exceed sixty (60) days for an infraction of the Association's published rules and regulations.

Section 3.4 Annual Meeting. The annual meeting of the Members of the Association shall be held at such place and on such date and time as established by the Board of Directors from time to time for the purpose of electing the Board of Directors of the Association and for the transaction of such other business as may come before the meeting. If a quorum is not present for the election or transaction of business on the day designated herein for the annual meeting of the Members, the Members shall cause the annual meeting to be held at a special meeting of the Members as soon thereafter as it may conveniently be held. Notwithstanding the foregoing, no annual meetings of the Members shall be required for so long as Declarant shall be the only Member of the Association entitled to vote or until it waives, in writing, its right to be the sole voting member.

Section 3.5 Special Meetings. Special meetings of the Members may be called by or at the request of the President or a majority of the Members upon the written demand, signed, dated and delivered to the Secretary. Such written demand shall state the purpose or purposes for which such meeting is to be called. The time, date and place of any special meeting shall be determined by the Board of Directors, or, at its direction, by the President.

Section 3.6 Notice of Meetings. Written notice stating the place, date and time of each annual meeting and special meeting and, in the case of a special meeting, the purpose or purposes for which the meeting is called, shall be given not less than five (5) days and not more than fifty (50) days before the date of the meeting, delivered personally or mailed to each Member at his or her personal or business address. Such notice shall be deemed to be delivered when deposited in the United States mail so addressed, with postage thereon prepaid.

Section 3.7 Quorum. Twenty-five percent (25%) of the number of the Members shall constitute a quorum for the transaction of business at any meeting of the Members, but if less than the required quorum is present at a meeting, a majority of the Members present may adjourn the meeting without further notice. If the required quorum is not present another meeting may be called subject to the same notice requirement, and the required quorum at the subsequent meeting shall be fifty percent (50%) of the required quorum at the preceding meeting. No such subsequent meeting shall be held more than sixty (60) days following the preceding meeting. Subject to Section 3.3 of this Article, if a quorum is present, the affirmative vote of a majority of the number of the Members shall be the act of the Members.

Section 3.8 Presumption of Assent. A Member of the Association who is present at a meeting of the Members at which action on any matter is taken shall be presumed to have assented to the action taken unless the Member's dissent shall be entered in the minutes of the meeting or unless the Member has submitted written dissent to such action with the person acting as the secretary of the meeting before the adjournment thereof or shall forward such dissent by registered mail to the Secretary of the Association immediately after the adjournment of the meeting. Such right to dissent shall not apply to a Member who voted in favor of such action.





## ARTICLE IV. BOARD OF DIRECTORS

Section 4.1 General Powers. The business and affairs of the Association, shall be managed by its Board of Directors. The Board of Directors shall manage the business and affairs of the Association in such a manner so as to comply with the meaning of the terms and limitations of the Articles of Incorporation, these Bylaws and the Declaration of Submission of Property to Horizontal Property Regime so that such actions will not jeopardize the federal income tax exemption of this Association pursuant to the provisions of Section 528 of the Internal Revenue Code as now in force or as may be amended.

Section 4.2 Number, Tenure and Qualifications. The Board of Directors of the Association shall initially consist of one (1) Director, which number may be changed from time to time by vote of the Members of the Association. The Directors shall serve for a term of one (1) year commencing with appointment or until a successor shall have been appointed or elected and qualified.

Section 4.3 Appointment of Board of Directors. The Declarant shall appoint the Board of Directors of the Association and determine the number of Directors of the Association for so long as it holds title to any Unit or until it waives, in writing, its right to be the sole voting member.

Section 4.4 Annual and Regular Meetings. An annual meeting of the Board of Directors shall be held without notice immediately after, and at the same place as the annual meeting of the Members for the purpose of organization, election of Officers and the transaction of other business. Regular meetings of the Board of Directors may be held at such time and place as the Board of Directors shall by resolution fix and determine from time to time without other notice than such resolution.

Section 4.5 Special Meetings. Special meetings of the Board of Directors may be called by or at the request of the President or a majority of the Directors. The person or persons authorized to call special meetings of the Board of Directors may fix any place, either within or without the State of Iowa, as the place for holding any special meeting of the Board of Directors called by them.

Section 4.6 Notice. Notice of any special meeting shall be given not less than five (5) days and not more than fifty (50) days before the date on which the meeting is to be held, by written notice delivered personally or mailed to each Director at his/her personal or business address. Such notice shall be deemed to be delivered when deposited in the United States mail so addressed, with postage thereon prepaid. Any Director may waive notice of any meeting. The attendance of a Director at a meeting shall constitute a waiver of notice of such meeting, except when a Director attends a meeting for the express purpose of objecting to the transaction of any business because the meeting is not lawfully called or convened. Except as otherwise provided in these Bylaws, neither the business to be transacted at, nor the purpose of, any regular or special meeting of the Board of Directors need be specified in the notice or waiver of notice of such meeting.

Section 4.7 Quorum. A majority of the number of Directors shall constitute a quorum for the transaction of business at any meeting of the Board of Directors, but if less than such majority is present at a meeting, a majority of the Directors present may adjourn the meeting without further notice. At all meetings of Directors, a quorum being present, the act of the majority of the Directors present at the meeting shall be the act of the Board of Directors.



Section 4.8 Presumption of Assent. A Director of the Association who is present at a meeting of the Board of Directors at which action on any matter is taken shall be presumed to have assented to the action taken unless the dissent shall be entered in the minutes of the meeting or unless the Director submits a written dissent to such action with the person acting as the secretary of the meeting before the adjournment thereof or shall forward such dissent by registered mail to the Secretary of the Association immediately after the adjournment of the meeting. Such right to dissent shall not apply to a Director who voted in favor of such action.

Section 4.9 Action Without Meeting. Any action required to be taken at a meeting of the Directors, or any other action which may be taken at a meeting of the Directors, may be taken without a meeting if a consent in writing, setting forth the action so taken, shall be signed by all of the Directors entitled to vote with respect to the subject matter thereof. For purposes hereof, facsimile signatures shall be adequate to show consent.

Section 4.10 Resignation and Removal. Any Director may at anytime resign by serving written notice thereof on the remaining Directors. A Director may be subject to removal, with or without cause, at a meeting of the Members called for that purpose in the manner prescribed by law. A Director who misses more than three (3) consecutive board meetings will be subject to removal upon resolution by the Board of Directors.

Section 4.11 Vacancies. Subject to Section 4.3 of this Article, any vacancy occurring in the Board of Directors and, to the extent permitted by law, any Directorship to be filled by reason of an increase in the number of Directors, may be filled by election by a majority of the then sitting Directors of the Association. A Director so elected shall serve the unexpired term of his/her predecessor in office or the full term of such new Directorship, as the case may be.

Section 4.12 Compensation. Directors shall serve without compensation, except reasonable expenses may be paid. However, to the extent deemed necessary by the Association, the Association may retain the services of a Director other than in the capacity as a Director and the Director may be compensated for services so rendered as the Board of Directors may from time to time deem appropriate.

## ARTICLE V. OFFICERS

Section 5.1 Designation of Officers, Election and Term of Office. The Officers of the Association shall be a President, a Vice President, a Secretary and a Treasurer. Any two or more offices may be held by the same person. The Officers shall be elected annually at the annual meeting of the Board of Directors held after the annual meeting of the Members and each Officer shall hold office until a successor shall have been duly elected and qualified or upon death, resignation or removal.

Section 5.2 Management Company. So long as Declarant holds title to any Unit or until it waives, in writing, its right to be the sole voting member, the Board of Directors may, in its discretion, contract with a professional management company to manage the regular business and affairs of the Association and shall have other such powers and duties as the Board of Directors shall specify at the expense of the Association.

Section 5.3 Resignation. Any Officer may at any time resign by serving written notice thereof on the Board of Directors. Such resignation shall take effect upon receipt thereof or at any later



time specified therein; and, unless otherwise specified therein, acceptance thereof shall not be necessary to make it effective.

Section 5.4 Removal. Any Officer may be removed by the Board of Directors whenever in its judgment the best interests of the Association will be served thereby. Any Officer holding the position of President, Vice President, Secretary or Treasurer shall automatically be removed if the individual holding the subject office is no longer a Member.

Section 5.5 Vacancies. A vacancy in any office because of death, resignation, removal, disqualification or otherwise, shall be filled by the Board of Directors for the unexpired portion of the term.

Section 5.6 Salaries. The President, Vice President, Secretary and Treasurer shall serve with compensation which shall be fixed from time to time by the Board of Directors. Further, to the extent deemed necessary by the Association, the Association may retain the services of the President, Vice President, Secretary and Treasurer other than in their capacity as such Officers and they may be compensated for services so rendered as the Board of Directors may from time to time deem appropriate.

## ARTICLE VI. INDEMNIFICATION

Except for any prohibition against indemnification specifically set forth in these Bylaws or in the Revised Iowa Nonprofit Corporation Act at the time indemnification is sought by any member, director, officer, employee, volunteer or agent of the Association, the Association shall indemnify any person who was or is a party or is threatened to be made a party to any threatened, pending or completed action, suit or proceedings, whether civil, criminal, administrative or investigative (other than an action by or in the right of the Association) by reason of the fact that the person is or was a member, director, officer, employee, volunteer or agent of the Association, or is or was serving at the request of the Association as a member, director, officer, employee or agent of another Association, partnership, joint venture, trust or other enterprise (such serving as a member, director, officer, employee or agent of the Association or at the request of the Association referred to herein as "serving on behalf of or at the Association's request"), against expenses (including attorneys' fees), judgments, fines and amounts paid in settlement actually and reasonably incurred in connection with such action, suit, or proceeding if the person acted in good faith and in a manner reasonably believed to be in or not opposed to the best interests of the Association, and with respect to any criminal action or proceeding, had no reasonable cause to believe the conduct was unlawful. The termination of any action, suit or proceeding by judgment, order, settlement, conviction, or upon a plea of nolo contendere or its equivalent, shall not, of itself, create a presumption that the person did not act in good faith and in a manner reasonably believed to be in or not opposed to the best interests of the Association, and, with respect to any criminal action or proceeding, had reasonable cause to believe that person's conduct was unlawful.

## ARTICLE VII. SEAL

The Association shall have no corporate seal.



## ARTICLE VIII. AMENDMENTS

These Bylaws may be altered, amended or repealed and new Bylaws may be adopted at any regular or special meeting of the Members only upon the affirmative vote of not less than two-thirds (2/3) of all of the votes of the Members entitled to vote, whether in person or by proxy at a meeting duly called for this purpose. No such amendment, however, shall conflict with or minimize the intended effect of the provisions of the Articles of Incorporation of the Association or the Declaration. The President, a Vice President or Secretary may prepare, execute and certify any amendment to these Bylaws.

Amendments to the Declaration may be prepared, executed, recorded and certified on behalf of the Association by any Officer of the Association designated by resolution of the Board of Directors for that purpose or in the absence of any such designation, by the President of the Association.

Dated June 22 2020.

  
\_\_\_\_\_  
Steve Bruere, Director

